

L series 1/1 online UPS (1KVA~20KVA)



User's Manual

Table of contents

1. Importance indication	3
1.1. Applied condition	3
1.2. Working environment	3
1.3. Safety notice	3
2. Product information	4
2.1. How to name the UPS	4
2.2. Main features	5
2.3. Technology parameters	6
3. UPS appearance introduction	8
3.1. 1~3KVA UPS	8
3.2. 4~20KVA UPS, 6~20KVA UPS	8
3.3. Front panel operation instruction	9
4. Brief introduction of UPS configuration	11
4.1. Rectifier	11
4.2. Inverter	11
4.3. Battery	12
4.4. Switch	12
4.5. Displaying and touching screen operation	12
4.6. L series 1/1 large screen LCD display and operation	13
4.7. RS232 intelligent communication	23
4.8. RS485 intelligent communication	24
4.9. Communication of SNMP and distant web	24
4.10. Dry connect state communication	25
5. UPS Working principle	26
5.1. Working principle of complete machine	26
5.2. Mains operational mode	28
5.3. Battery inverter operational mode	28
5.4. Bypass operational mode	28
5.5. Manual maintenance bypass mode	28
6. UPS installation	29
6.1. Disassemble and inspect	29
6.2. UPS positioning	30
6.3. UPS wires connection	30
6.4. Connection inspection	33
7. Operation and management	33
7.1. Preparations before turning on the machine	33
7.2. The first time turn on the UPS	34
7.3. Test in AC mode operation	34
7.4. Test in battery mode operation	34
7.5. Daily operation management	34
8. Daily maintaining	35
8.1. Defance maintenance	35
8.2. Battery maintaining	35
8.3. The explanation of alarm	35
9. Packing list	42

1. Importance indication

This manual contains the guidance of UPS and accumulator when installation and application, also includes the guidance of problem setting and maintenance.

- ∅ Please read this user manual carefully before using or installing the machine.
- ∅ This manual must be read to and conserved by a professional person.
- ∅ This manual does not introduce the specified technologies.
- ∅ This manual applies to the L series 1/1 online UPS.

This manual provides the reference when using and guidance when alarming and working.

1.1. Applied condition

This UPS provides AC power supply, which is the basic power of your equipment. Please carefully check whether the input and output pressure and frequency can meet the using requirements.

UPS input AC capacitor must be as requested. Otherwise the UPS will work improperly or even occur security accident (when the UPS input is generator, generator capacity should be 3 multiple more than UPS).

1.2. Working environment

The working environment and maintain methods also influent the using age and failure rate of the UPS. Therefore, please avoid the following working environment in long term.

- Places over demand of specifications (temperature 0°C~40°C, relative humidity 30%~95%).
- Places with bare sunshine.
- Places near by the heat sources. Over heat will speed up the external battery self-discharge.
- Places liable to shaking and shoving.
- Places have powder, corrosive substances and combustible gas.

1.3. Safety notice

1.3.1. Generally the UPS is in connection with batteries. So that there might still be voltage in the output end even without AC input.

1.3.2. When UPS need to be moved or re-wiring, you must ensure that all UPS stop working, electricity input and batteries input is off. Otherwise, there may still be risk of electric shock in the output end.

1.3.3. To ensure the person's safety, this series UPS must be of good grounding protection and of reliable grounding before the using.

1.3.4. Please keep the air intake and exhaust open. Poor ventilation will increase the internal temperature of the UPS and therefore short the lifetime of UPS spare parts.

1.3.5. Liquid and other objects should not be leaked into the inside UPS inside box.

1.3.6. In case of fire broken out around, please use dry powder fire extinguisher. Liquid fire extinguisher will be danger of electric shock.

1.3.7. The life time of product will decrease by the increasing of temperature. Regular replacement could guarantee UPS work normally and maintain sufficient time. Replacement the battery must be operated by authorized technologists.

1.3.8. If no use it long time, UPS must be stored in dry environment, the host (without batteries) the storage temperature range: -40 °C~+70 °C.

1.3.9. In term of no use the UPS for long time, it is advised to charge it by AV for more than 12 hours every 3 months. To avoid any battery damage for long time no using.

1.3.10. Please do not open the battery cabinet in case that the electrolyte injury the skin and eye. If incaution the body contact the electrolyte, please wash it with plenty of water and then go to the hospital.

1.3.11. Please do not open the cabinet by yourself because there are many high voltage accumulator spare parts. Otherwise any accident arisen should at your peril.

1.3.12. Please do not disassembly any connection cable by yourself without permission.

1.3.13. Because this UPS is very big and heavy, please do not move and shake it violently. Also good ventilation is necessary.

1.3.14. Do not exhaust the dust when it is electrophorus. Do not use wet washrag to clean the dirt.

1.3.15. The battery must be replaced by professional technologist. Replaced battery should be send to special recycling agencies. Battery belongs to toxic waste.

2. Products information

L series 1/1 UPSs are with a power range from 1KVA to 20KVA. L series 1/1 UPSs adopt high-speed MCU and CPLD programmed and controlled by software. L series 1/1 UPSs bring in the sixth generation low-exhaust and big-power IGBT and static switch as power components. L series 1/1 UPSs combine world's newest control spare parts and the most advanced software, and apply broadly to industrials such as building lighting, road traffic lighting, electricity, industry and other industrial and mining enterprises fields.

2.1. How to name the UPS

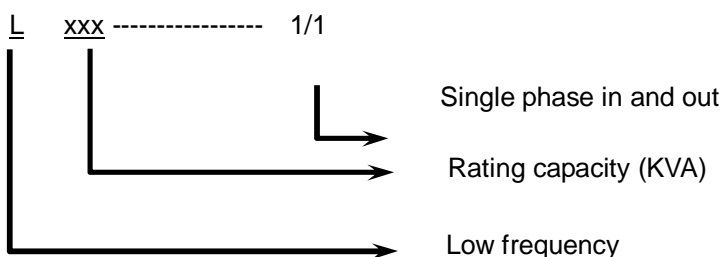

UNINTERRUPTIBLE POWER SUPPLY

Name: UPS

Type: L**K

Input voltage: 220VAC±20% , 50Hz

Output voltage: 220VAC±2% , 50Hz

Battery voltage: 192VDC

Production date:

Production number: PCUPSTT400K060508001



PC1215400K9H060508

Name——UPS;

Type——it means the UPS's rating capacity; please refer to the product naming regulation.

Input pressure——rating input pressure and frequency

Output pressure——rating output pressure and frequency

Battery pressure——rating battery pressure

Production date——leave factory date

Production number——production serial number

Code number——CODE-39 standard

2.2. Main features

I Online working pattern and prompt static switch

I Intelligent digital control technology

It adopts 3 high-speed microprocessor controlling system and operation parameters which make its operation & management more perfect and its self-diagnosis and self-detect function stronger. You can also fully trust the sine wave which was converted by figure voltage to operate perfectly and meet your demand.

I Efficient IGBT inverter AB technology

I High-speed switch feature of IGBT; high voltage and large current; adopt voltage drives, only needs little control power. With lower saturation voltage of the fifth IGBT, the inverter AB works more efficiency and reliable.

I Superior load

It is completely capable to load from 0-100% while no need to change to bypass, which make sure the output reliable.

I Intuitive view of the LED working state and work flow

I Humanized big touch screen LCD in both Chinese and English

It provides intuitive view of intelligent icon status of the flow chat, tabular data, events records and menu operation in both Chinese and English.

I Perfect protection

It has output over/low load protection, input surge protection, phase sequence protection; battery over charge/discharge protection; short circuit protection; over-temperature protection and so on, as well as alarming function.

I High dynamic performance

Adopting kinds of feedback control such as instantaneous control method and valid date, it achieves high dynamic adjustment and reduces the output THD.

I Adopt 6 pulse rectifier (option 12 pulse and input harmonic filter)

Effectively restrain the input THD; raise UPS input power factor, reduce the input THD current.

I Intelligent battery management

L series 1/1 UPSs can automatically adjust battery charge parameters according the user's battery configuration, and can achieve battery float and boost conversion, temperature compensation and battery charge& discharge management according to the power supply environment. It prolongs the battery's lifetime and reduces the operator's burden.

I Optional battery detecting module

It is able to test the single parameter, and display on the LCD. If battery failure it will alarm to runner.

I Intelligent detection function

The system microprocessor will continuously detect on line all power's supply working status, breaker status, and all circuits working status. Any failure occurs, the detecting system will immediately alarm to the runner.

I Intelligent communication

RS232 and RS485 interface realizes multi-communication and long distance monitor.

The choice SNMP card 100% carries out long distance supervision and network management; the optional dry contact connection, adopting no have no the source, efficiently carries out the supervision and control of the UPS status.

I Characteristic setting

As per different power supply, the UPS can adjust the input parameters.

2.3. Technology parameters

(1) Rectifier parameters

Type	L1K	L2K	L3K	L4K	L6K	L8K	L10K	L15K	L20K	L30K
Range(KVA)	1	2	3	4	6	8	10	15	20	30
Input capacity(A)	6	12	18	24	35	45	57	86	114	172
Working	Pure sine wave									
Phase	1 phase+N+G									
Voltage	220VAC±25%(UPS mode), 220VAC±10%(ECO or UPS mode)									
Frequency	50Hz±10%, 60Hz±10%(UPS mode) 50Hz±5%, 60Hz±5%(ECO or UPS mode)									
THDi	<5%									
Soft start	0~100% 5s									
Output voltage	55 VDC					220VDC				
Set the DC voltage by soft	42-60VDC/200~232VDC(change them by the professional engineer with the soft)									

(2) Battery and charge parameters

Type	L1K	L2K	L3K	L4K	L6K	L8K	L10K	L15K	L20K	L30K
Max current discharge(A)	24	48	71	24	36	48	60	90	120	179

Battery type	Maintenance-free lead acid battery	
Battery numbers	4pcs	16pcs
DC voltage	48VDC	192VDC
Float voltage	55VDC/220VDC(once of three months charge, charge vottage 56.8/232VDC)	
Charge power	Rated powerX20%(automatically change follow the batteries)	

(3) Inverter parameters

Type	L1K	L2K	L3K	L4K	L6K	L8K	L10K	L15K	L20K	L30K
Rated power Cosφ=0.8	Capacity ×0.8(KW)									
Phase	Single phase(L+N+G)									
Voltage	220±1%(state load, 220±5%(fluctuate load))									
Frequency	50Hz±0.5%, 60Hz±0.5%(with battery)									
Output frequency stability	<±0.5%(no in phase)									
Input frequency	50Hz±5%									
Crest factor	3: 1									
Wave	Pure sine wave									
Output waveform distortion	Pure sine wave, linear load<3%; non-linear load<5%									
Dynamic characteristics	<±5%(0←→100% load)									
Recover time	<10ms									
Overload	125% 1 minute, 150% 1s									
Inverter efficiency	≥95% (load 100%)									

(4) Bypass parameters

Type	L1K	L2K	L3K	L4K	L6K	L8K	L10K	L15K	L20K	L30K
Phase	Single phase									
Voltage	220VAC±25%(UPS mode), 220VAC±10%(ECO or UPS mode)									
Frequency	50Hz±10%, 60Hz±10%(UPS mode) 50Hz±5%, 60Hz±5%(ECO or UPS mode)									
Transfer time	<1ms (inverter←→bypass)									

(5) System parameters

Type	L1K	L2K	L3K	L4K	L6K	L8K	L10K	L15K	L20K	L30K
Efficiency	>80%(100% load)									
Communication	RS232/RS485, (SNMP option)									
Temperature	0~40℃									

Relative humidit(no coagulation)	30%~90%									
Height(Max)	<1000M(a 1% decrease against 100 meters' rise; altitude 4000M Max)									
Cooling down method	Compulsive ventilation(with temperature control)									
Noise dB	40~50			50~55			55~60			
Cabinet colors	Grey(option other colours)									
Input place	Under/back									
Easy to maintain	Top/left or right side open									
Cabinet size W×D×H(mm ³)	210×495×500			210×580×540		380×680×900			430×750×1050	
Weight(Kg)	38	45	60	105	138	155	185	215	245	318
Input mode	With the line connection									
Output mode	With the line connection									

All the above parameters are reference only, any difference please refer to the actual UPS.

3. UPS appearance introduaction

3.1. 1~3KVA UPS

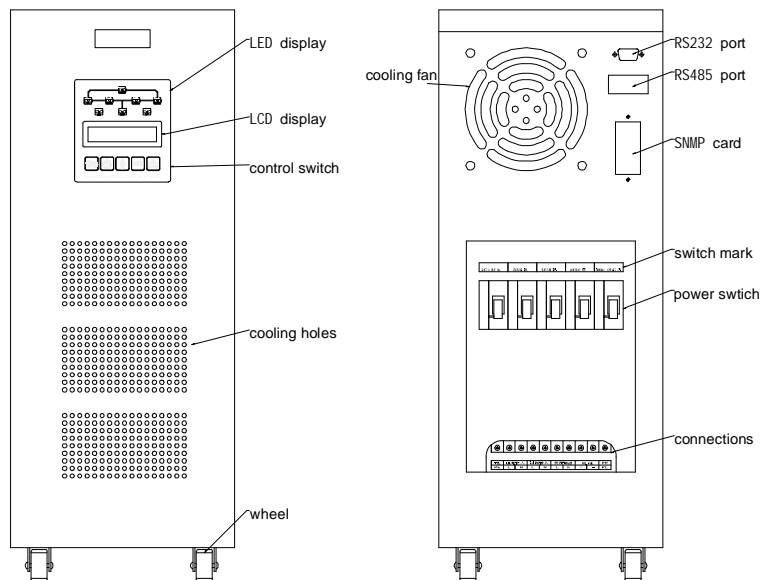



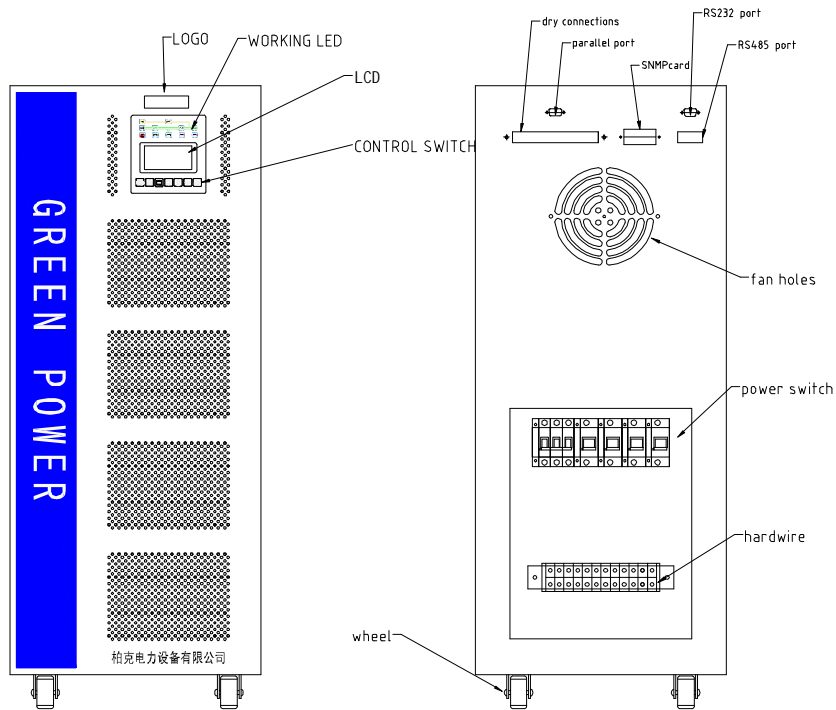





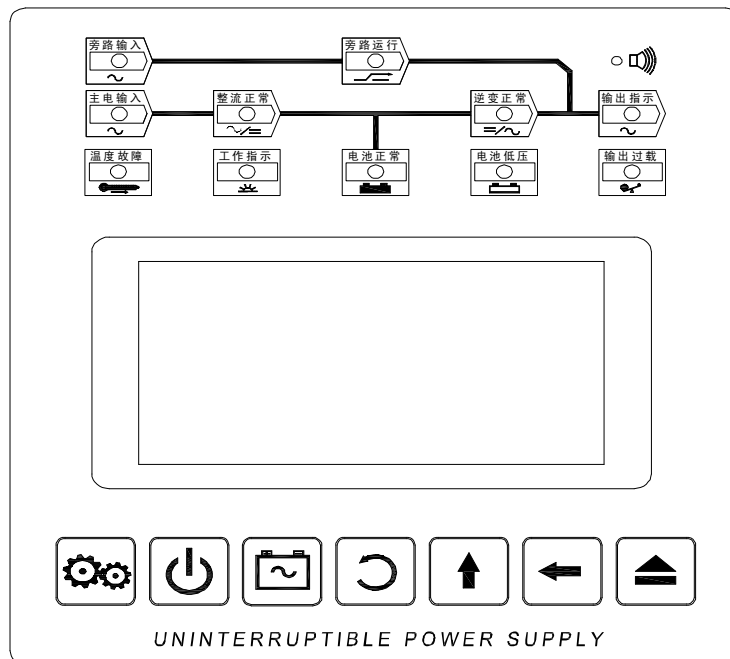

3.2. 4~20KVA UPS, 6~20KVA UPS



3.3. Front panel operation instruction

3.3.1. Single phase in and out front panel operation instruction



- I  is function key, take the key for 5 seconds as the ups turning off then you can enter the seting status.
- I Take the  +  at the same time is turning off the UPS, UPS will be bypass.
- I  is ON key, take it for 2s, UPS will turn on and from bypass to inverter normallyafter 1 minute.
- I  is ON key with BAT, pls take the key for 1s when you want to start the ups without the mains.
- I  is reset key, take the key for restart the UPS.
- I  is up the number key, when the seting status pls use it.
- I  is moving the cursor key, when the seting status pls use it
- I  is turning over the screen key, mainly use to turn over the screen for looking the UPS working status.

3.3.2. Led display introductions

A. Working status lamp -- indicate each part of the circuit working status when it works.

- Ø Bypass input -- lightens when bypass input power's voltage and frequency are within normal range.
- Ø Bypass operation -- lightens when static switch is bypass working status.
- Ø Main power input -- lightens when main input power's voltage and frequency are within normal range.
- Ø Rectifier normal -- lightens when rectifier works normally.
- Ø Inverter normal -- lightens when inverter works normally.
- Ø Input indication -- lightens when UPS inputs.
- Ø Wrong phase order -- lightens when input AC's phase order has error.
- Ø Working status -- lightens when controlling circuit of the whole machine works normally.
- Ø Battery normal -- lightens when battery's voltage works normally.
- Ø Low voltage -- lightens when the voltage of the battery is low.
- Ø Overloaded input -- lightens when the input is overloaded.

B. Screen plus LCD

- Ø Touch screen -- you can touch directly on the screen board and enter into the corresponding menu.
- Ø LCD -- show the status and figures.

C. Details please refer to the part of display and communication.

- Ø Rectifier switch -- the breaker controls the rectifier's input. Meanwhile it protect the rectifier: the breaker cuts when the rectifier is over current.
- Ø Bypass switch -- the breaker controls the bypass's input and protect the bypass meanwhile. The breaker cuts when bypass circuit is over current.
- Ø Battery's switch -- the breaker controls the battery's input and protects the battery group meanwhile. The breaker cuts when battery group is over current.
- Ø Input switch -- the breaker controls the UPS's AC output and protects the output meanwhile. The breaker cuts when input over current or short circuit.
- Ø Maintain switch -- it is used for maintain UPS with uninterruptible power, it will turn off when working normally. Please refer to correct flow when using this swift, otherwise it will cause the failure of UPS or output cut.

The process of cut off the maintainence switch: turn on the bypass switch, meanwhile turn off the inverter by manual, then turn off the output switch, the cut off the maintainence switch, and then turn off the rectifier switch and battery switch.

- D. Connection end -- cables connect the input, output and battery.
- E. Dry connection point connections
- F. RSS232 communication meet end -- connect the RS232 meet end in the computer. It will monitor the UPS in background through monitor software.
- G. RS485 communication meet end -- connect the RS485 meet end in the computer. It will monitor the UPS in background through monitor software.
- H. SNMP card -- connect the Intel website and operate the web long-distance monitor.
- I. Boarding -- open it and screw and connect lines
- J. Idler wheel -- to move the UPS when installing. Should be fixed after installation.

4. Brief introduction of UPS configuration

4.1. Rectifier

Convert the 1 phase's input AC electricity into stable DC through the rectifier and charge the battery meanwhile. Its consisted parts are as following:

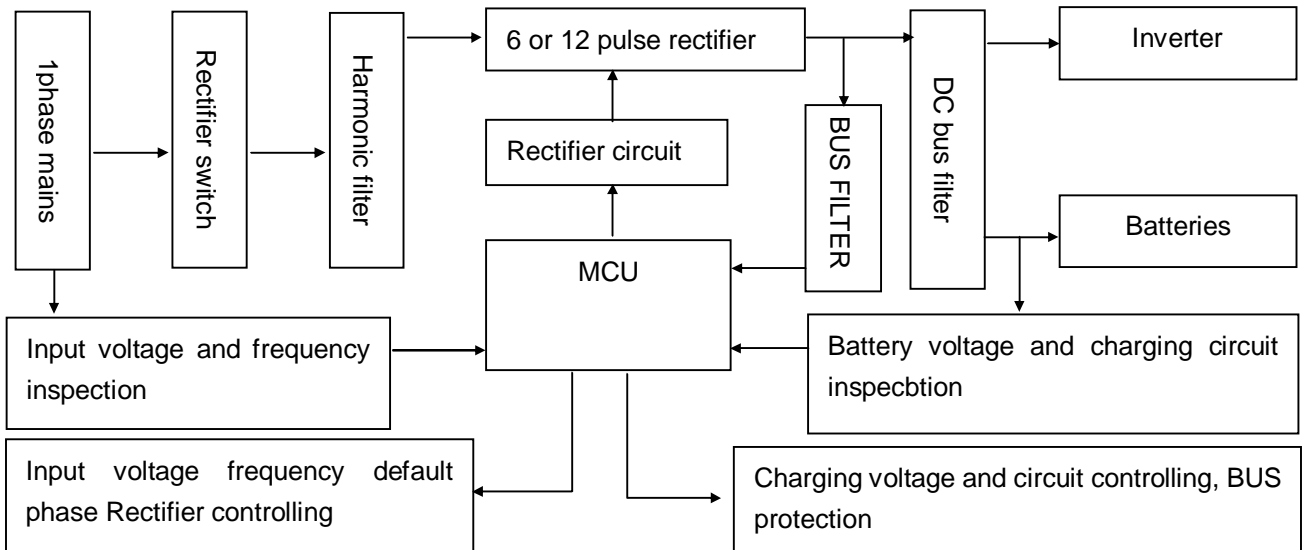

As the above chart, controlled by input through rectifier switch, the main power was rectified to DC firstly by harmonic filter and secondly the 6 or 12 pulse rectifier. At last it was rectified to stable DC bus by harmonic again. Though measuring the input voltage and frequency and DC bus and controlling the rectifier, the commutating control circuit input stable DC to inverter and battery group. Meanwhile it starts protection when I/P wrong phase, be lack phase and over limited.

4.2. Inverter

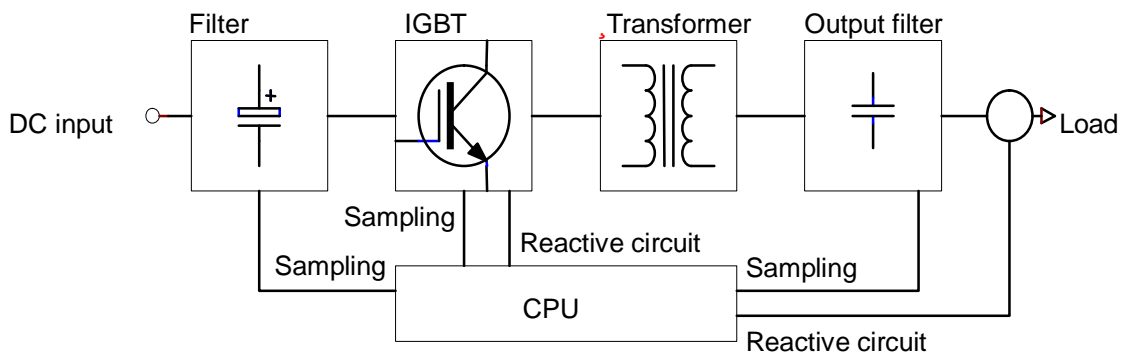

Be consist of sampling circuit, single-chip controlling circuit, IGB driving circuit, IGBT module, inverter isolating transformer, filter inductance and protecting circuit. Microprocessor firstly produce the SPWM signal through computing the sampling signals, and meanwhile drive the IGBT module bas AC and change it into high frequency SPWM waves. Secondly it output pure sine AC through inverter isolating transformer, inverter filter. At the same time it adjust the output voltage and waves' shape via the feedback of sampling signals such as voltage, current and temperature.

4.3. Battery

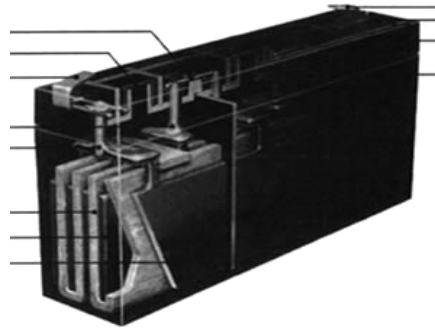

Battery is consisted of the power slot (plastic crust), the cathode plate, the negative electrode, separator, electrolyte, inter-unit bridge, terminations, safety valves and other components. It is a power and chemical energy conversion devices. The working principle is, when AC is normal the charger will charge and the battery will convert the power to chemical energy which will be stored in the battery; when the AC works abnormally the battery will convert the chemical energy to power to UPS.

4.4. Switch

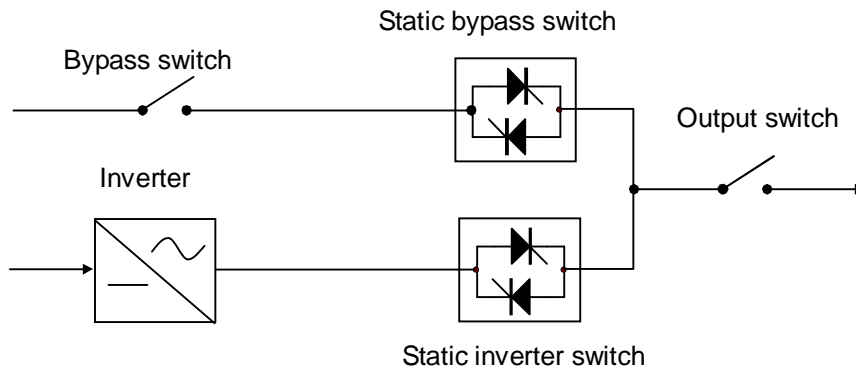

The UPS pattern is dual-mode transformation. When the inverter does not start it is bypass mode; after turning on the inverter it will high-speedily switch from static bypass switch to static inverter output switch. As static switch is electronic switch so there is no mechanical switching time.

4.5. Displaying and touching screen operation

4.5.1. Touching screen information

Touch-screen LCD monitors is our company's latest invention of the UPS modules, using today's most popular and intuitive graphical operation interface. Comparing with the traditional button-LCD display modules, the touch-screen display module shows a more rich content which avoids frequent page turning. At the same time because the user can get corresponding information by directly press the button on the display screen. It is easy to use easy to get. Meanwhile touch-screen display module comes with real-time clock and memory and can be recorded 256 incidents and other information, which is more humanize.

4.5.2. Operation and introduction

Stand by screen shown in chart 1. UPS will start up in the show this standby screen. When the touch-screen interval of about four minutes not to touch, shows CPU will automatically cut off power ----- touch screen backlight can be extended so the backlight life, and return to the standby interface (if UPS is in the police state, the touch screen will be Priority information shows that the police box, police information to repeal or abolish manual alarm will not be cut off before the show CPU touch screen backlight back to standby power supply interface).

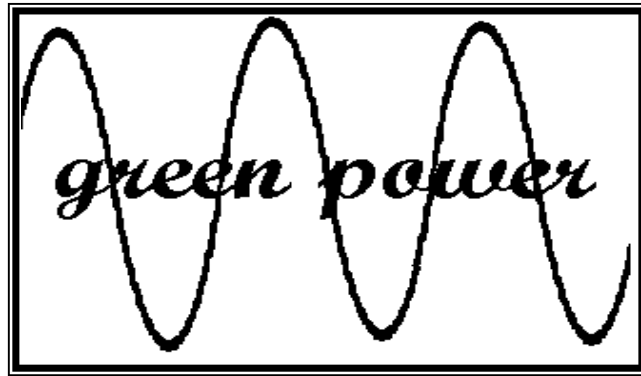

4.6. L series 1/1 large screen LCD display and operation

4.6.1 Standby interface

Standby interface see chart one. When turn on the UPS it will display the standby interface. When the LCD around 1 minute no one operation, the display CPU will automatically cut off the display back light...so as to enlarge the lifetime of back light, meanwhile back to the standby interface (if the UPS in alarm status, the display will prior to display the alarm information, before the alarm information withdraw or manual withdraw the alarm the display CPU will not cut off the LCD back light and back to the standby interface).

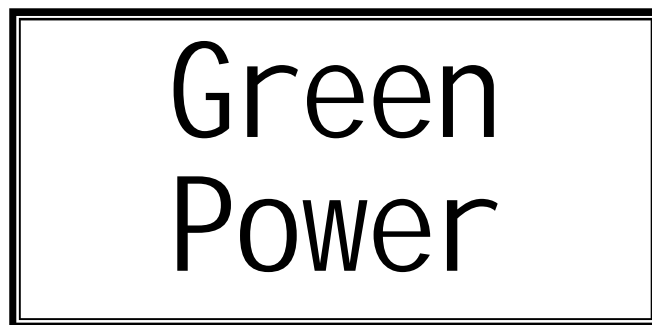



Chart 1

4.6.2. Flow chart display interface

Flow chart display interface see chart 2. In standby interface press the scroll key  enter into flow chart display interface. In this interface will see the UPS working working and operation statuses display. The meaning for each part of the interface as following

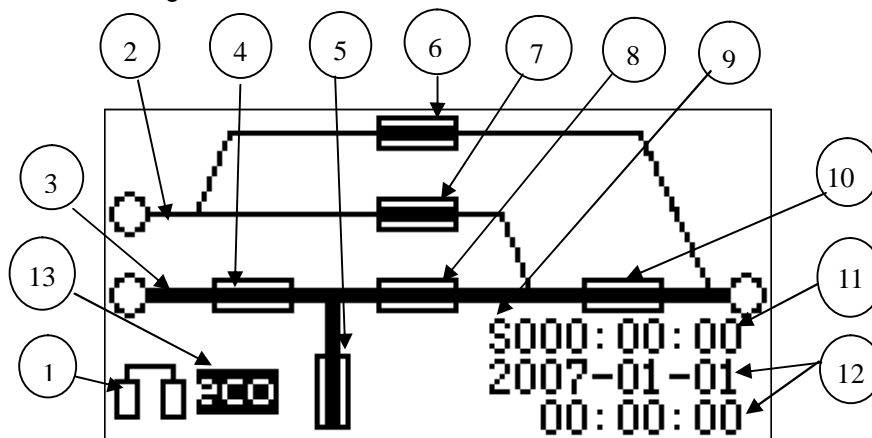



Chart 2

-
1. Subordinative unit mark: when the screen displays this mark, it shows that in parallel system this UPS in subordinative status.
 2. Thin real line: connect the no working module with thin real line shows this module already stop working.
 3. Thick real line: connect the working module with thick real line shows this module in working mode.
 4. Rectifier and input mark: in flow chart interface, it means rectifier module. If this mark flickers, it means input switch cut off.
 5. Battery batch and battery switch mark: in flow chart interface it means battery batch, if this mark flicker it means the battery switch cut off.
 6. Maintenance bypass switch: display the maintenance bypass switch status, if this mark flicker it means turn on the manual bypass.
 7. Bypass switch: display the bypass switch status, if this mark flicker it means bypass switch cut off.
 8. Inverter and DC fuse mark: in flow chart interface it means inverter module, if at the same time this mark flicker, it means DC fuse cut off.
 9. Count down turn on mark: when the LCD display S mark, it means the system enter into turn turn off status; when the LCD display R mark, it means the system enter into count down turn on status.
 10. Output switch: display the output switch status, when this mark flicker, it means the output switch cut off.
 11. Count down time: display the remaining time of count down to turn on/off.
 12. System time: display real system time
 13. Current working mode: if this mark displays eco, it means the system working in ECO mode; if display UPS, it means the system working in UPS mode, if no display then it means the system working in UPS mode.

4.6.3. UPS current operation status interface

UPS current operation status display likes chart 3. In flow chart interface press the the scroll key  and enter into operation status display interface. In this interface can see the UPS current operation status.

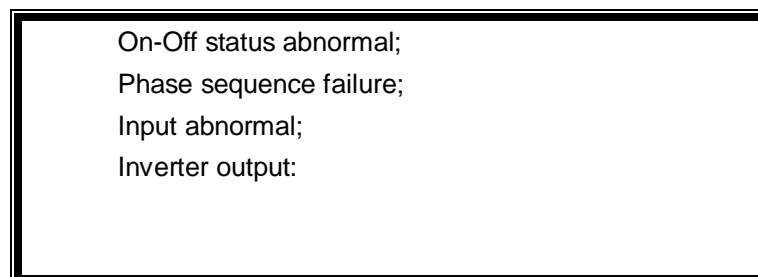



Chart 3

4.6.4. UPS input information display interface

When the UPS in operation status press the scroll key on the front panel  on the front panel then enter into UPS input information display interface, see chart 4. In this interface you can see the UPS current input information.

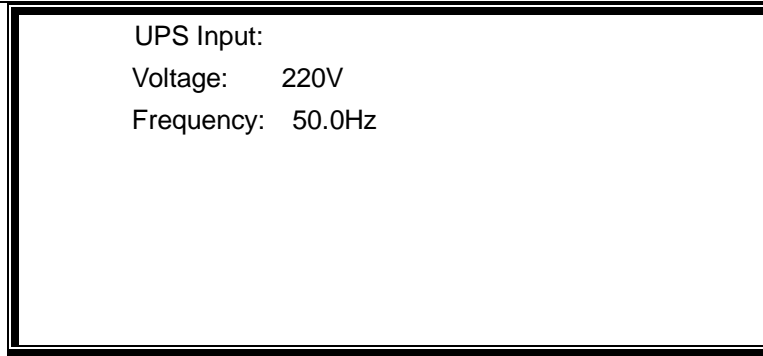



Chart 4

4.6.5. Inverter information display interface

In UPS input information display interface press the scroll key  on the front panel then enter into the inverter information display interface, see chart 5. In this interface you can see the inverter mode current information.

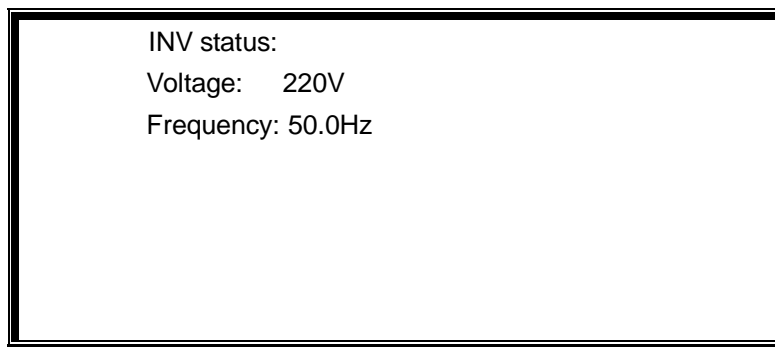



Chart 5

4.6.6 UPS output information display interface

In inverter display interface press the scroll key  enter into the UPS output information display interface, see chart 6. In this interface you can see the UPS current output information.

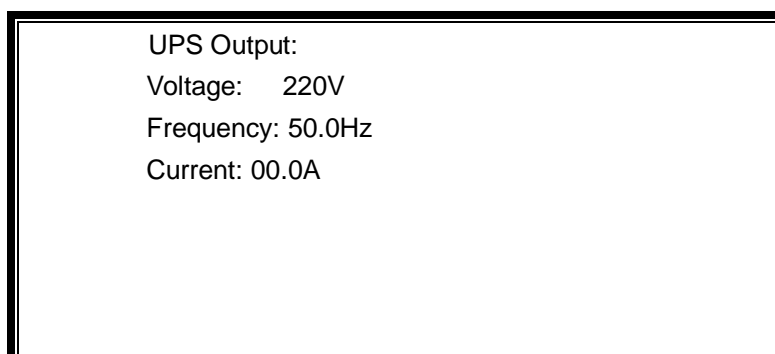



Chart 6

4.6.7. Temperature information display interface

In UPS output information display interface press the scroll key  then enter into the temperature information display interface, see chart 7. In this interface you can see the UPS current temperature information.

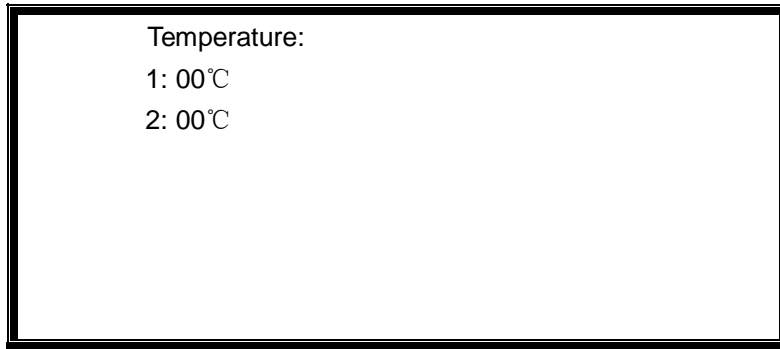



Chart 7

4.6.8. Battery information display interface

In the temperature information display interface press the scroll key  enter into the battery information display interface, see chart 8. In this interface you can see the battery batch current information.

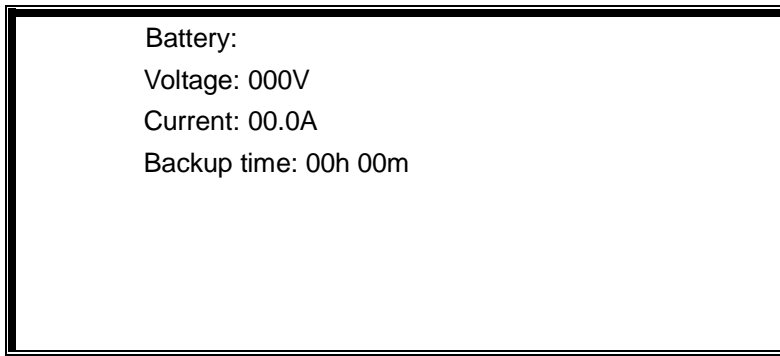







Chart 8

4.6.9. Back to standby interface

In battery information display interface press the scroll key  on the front panel then back to the standby interface.

4.6.10. Management setting optional interface

In the above any interface press the up key  or left key  enter into management setting optional interface, see chart 9. In this interface the selected content reverse video, use the up key  change the selectable content, use the left key  finish the selec. Use the scroll key  exit this interface back to the flow interface 4.6.2.

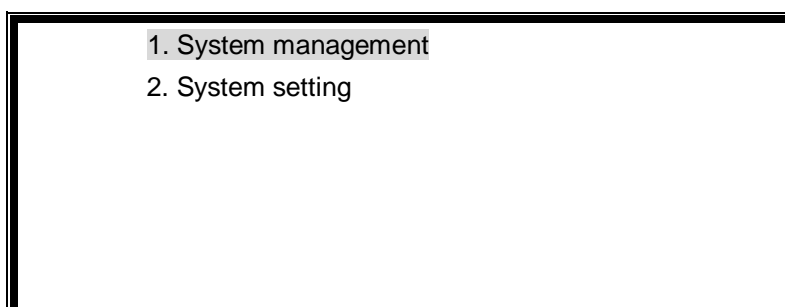





Chart 9

4.6.11. Management select interface

In the management setting interface select 1. system management .Then the LCD enter into management select interface, see chart 10. In this interface the selected content reverse video, use the up key  change the select content, use the left key  finish the select, use the scroll key  exit back to the previous interface 4.6.10.

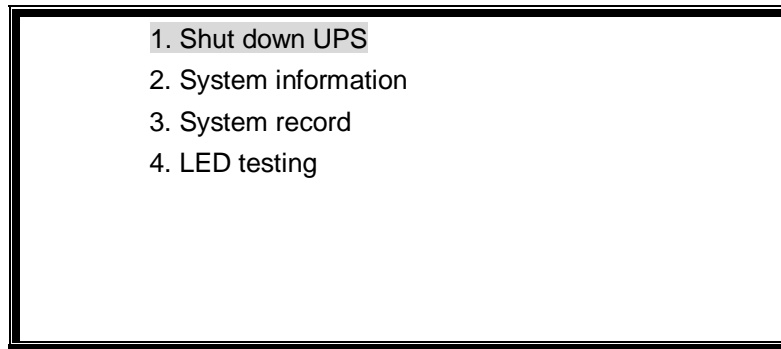





Chart 10

When UPS in working status, the first option is: 1. turn off UPS: When UPS in turn off status the first option is 1. start UPS.

4.6.12. Input password interface

In management select interface select 1. turn off UPS and enter into. This operation need input password. So the LCD enter into the password interface, see chart 11. In this interface the select content reverse video, use left key  remove cursor; use up key  increase the value or finish the select; use the scroll key  back to the previous interface 4.6.11.

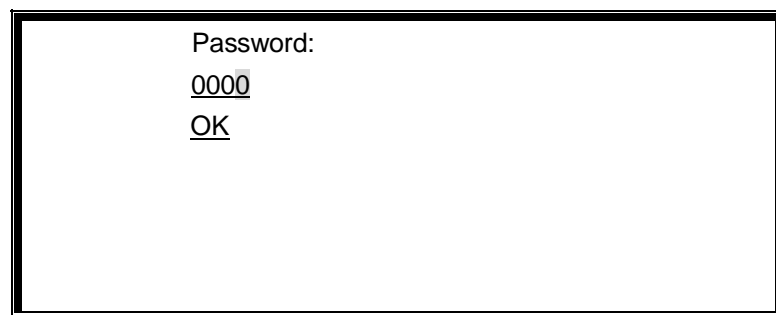



Chart 11

When move the cursor to OK, press up key  finish input password. If the password correctness will turn off/start, meanwhile back to the previous interface 4.6.11; if the password failure, the LCD will not alarm, and also clear the wrong password and reposition the cursor, UPS will in execution any operation. The nominal password of the system is: 1234.

4.6.13. System information interface

When manage the select interface choose 2. system information. The LCD will enter system information, see chart 12. In this interface will display the rated information of the system, use the scroll key  back to the previous interface 4.6.12.

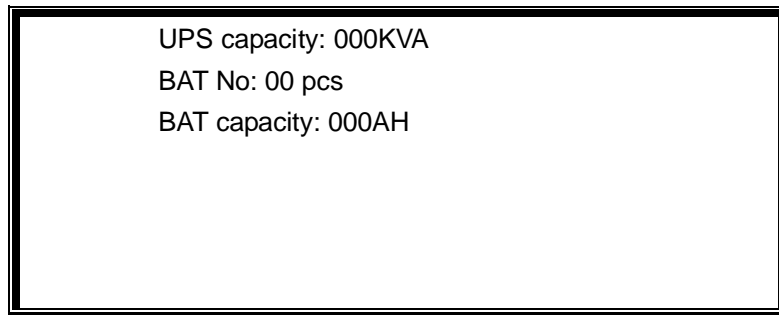





Chart 12

4.6.14. System record interface

In the management select interface choose 3. system record then the LCD will enter into the system record interface, see chart 13. In this interface will display all the record of the events. Use the up key  read the next record, use the left key  read the next nine records; use the scroll key  back to the previous interface 4.6.11.

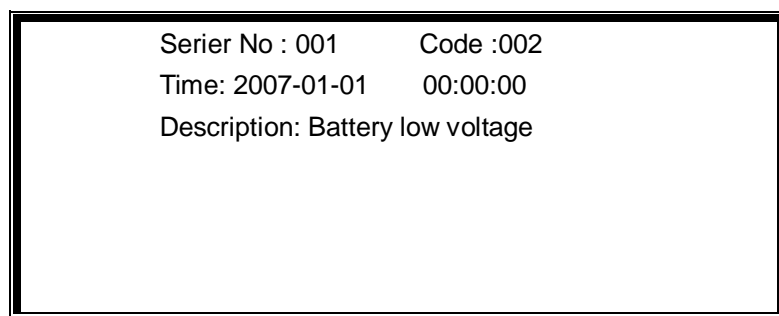





Chart 13

4.6.15. LED testing function

In the management select interface, choose 4. LED testing and enter. Testing the LED and the beeper for 6 mS on the front panel, during the testing period the LED light and the beeper beep.

4.6.16. Setting the select interface

In the management setting interface choose 2 system setting. The LCD enters into setting interface, see chart 14. In this interface the selected content reverse video, use the up key  change the optional content; use the left key  finish the select; use the scroll key  back to the previous interface 4.6.10.

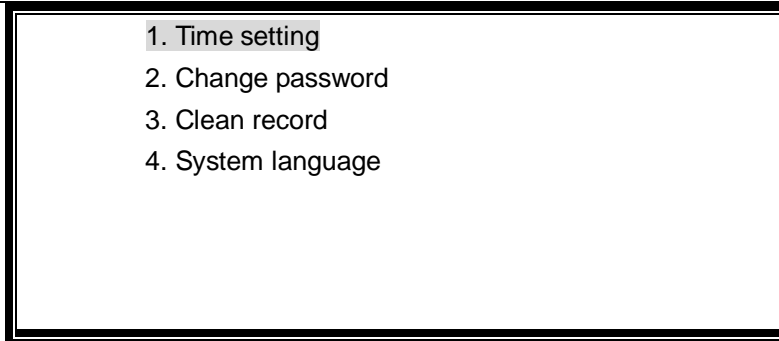





Chart 14

4.6.17 Clock setting interface

In the setting interface, choose 1 time setting. The LCD enters into clock setting, see chart 15, use the up key  change the select content, use the left key

-  Finish select, use the scroll key
-  Back to the previous interface 4.6.16.

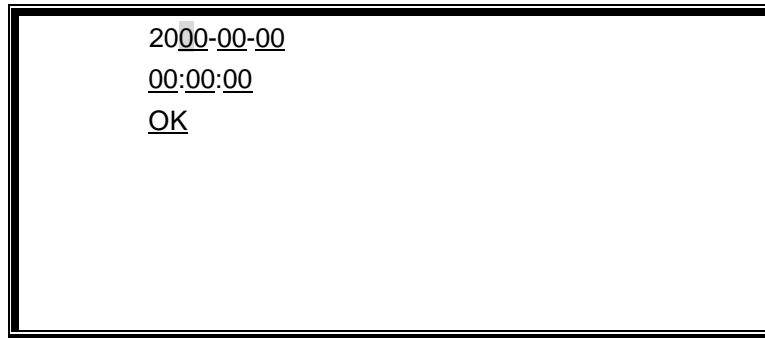



Chart 15

Use the cursor to **OK**.

Press the up key  finish the clock setting, input the correct time format, the LCD will update the time, also back to the previous interface 4.6.16.; if the time format not correct, the LCD will not display but clean all the input numbers and the cursor will reposition. LCD is inexecution any operation.

4.6.18. Change password interface

In the setting select interface 2, change password. The LCD enter into input password interface, the LCD enter into input password interface. The detailed operations see 4.6.12.

4.6.19. Leaning record interface

In the setting select interface choose 3.cleaning record. The LCD enters into input password interface. The detailed operations process reference to 4.6.12. After input correct password the system will clean all the records of the events, see chart 16. And the record is beyond retrieve, so the user should be more careful. When finish the delete, the LCD will automatically back to the management setting interface 4.6.16.

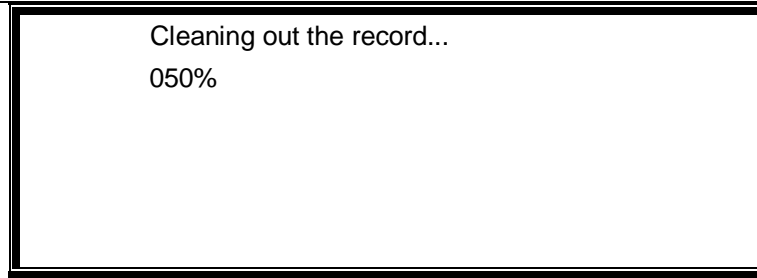





Chart 16

4.6.20. The interface of language setting

In the setting select interface choose 4. system language. The LCD enters into language select interface, see chart 17. In this interface the select content reverse video. Use the up key  change the select content; use the left key  finish the select; use the scroll key  back to the previous interface 4.6.16.

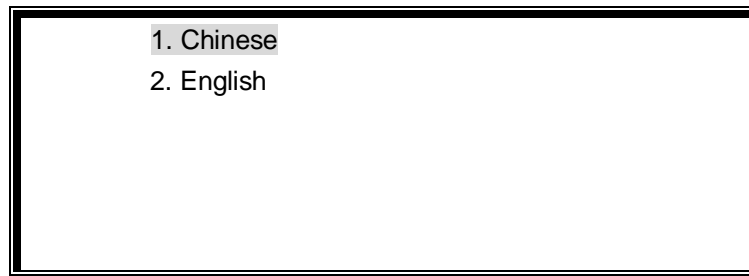



Chart 17

4.6.21. The interface of BAT code setting

When UPS in bypass mode press after 5 ms will enter into battery setting status, once the UPS enter into battery setting status, the LCD will automatically skip to this interface, see chart 18. In this interface the selected content reverse video. Use the left key  removes the cursor. Use the up key  increase the value or finish the select.

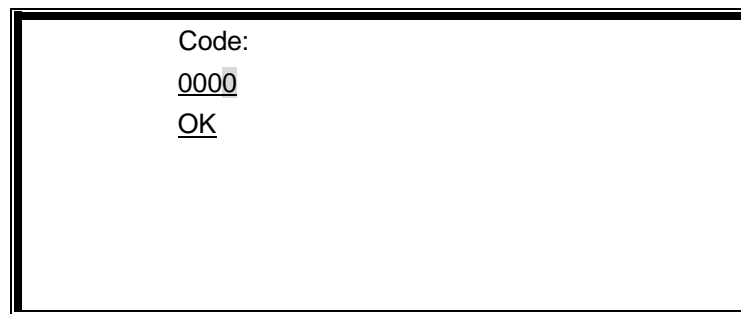





Chart 18

When the cursor on OK, press the up key  finish input the password. If the password correct, the LCD will automatically ship to the next previous 4.6.22. If the password is wrong, the LCD not displays, but cleans all the input password and reposition the cursor. LCD is inexact any operation. The nominal password is: 6666.

4.6.22. The interface of BAT capacity setting

The battery capacity setting interface, see chart 19. In this interface the select content reverse video, use the left key  move the cursor, use the up key  finish the select.

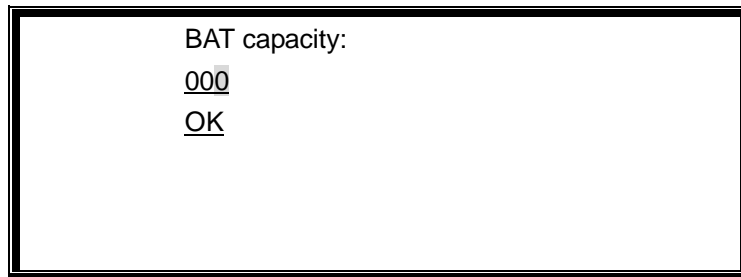





Chart 19

The user move the cursor to **OK**, press the up key  finish input the battery capacity. LCD will skip to the next interface 4.6.23.

4.6.23. The interface of working mode setting

Working mode setting interface, see chart 20. In this interface the selected content reverse video, use the up key  to move the cursor, use the left key  to finish the select.

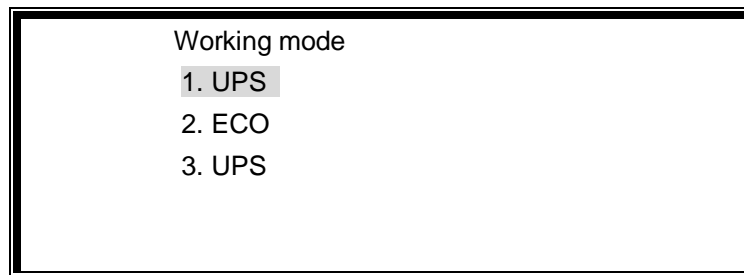



Chart 20

When the user move the cursor to the needed option, press the left key  to make sure the input setting working mode.

4.6.24. The interface of alarm

No matter what interface, once the UPS alarm, the LCD will prior to display alarm content, unless alarm withdraw or the user eliminate the beeper. The alarm interface display, see chart 21. Use the scroll key  to eliminate UPS alarm.



BAT voltage is low

OK

Chart 21

Code	Detail incident description
000	Blank, no record
001	Mains error
002	Battery voltage Low
003	UPS overloaded
004	Temperature error means temp high
005	Phase order error Phase order error: wrong input phase order
006	Inverter error
007	System error
008	Bypass output incident, means the UPS switch to bypass output
009	Inverter output incident means the UPS switch to inverter output
010	Rectifier error
011	Maintaining bypass switch is turning on
012	DC fuse is off
013	Rectifier switch is cut down
014	Bypass switch is turning on
015	Output switch is turning off
016	Battery switch is cut down
020	Batter switch is turning on
021	AC returns to normal
022	Battery voltage returns to normal
023	Load returns to normal
024	UPS temperature recover normal
025	UPS phase order returns to normal
026	Maintaining bypass switch is turning off
027	AC insurance returns to normal
028	Rectifier switch turning on
029	Battery switch turning on
030	Output switch turning on
031	Transmission error
032	Transmission returns to normal
041	Turning off automatically, means the machine is automatically shut down because of low UPS voltage or other error, and switch to bypass output
042	UPS restart
043	UPS enter battery testing status
044	Cancel buzzer alarming manually

045	Turn off UPS manually
051	User sends distant count down UPS turning off command from the monitor end
052	User sends distant count down UPS turning on command from the monitor end
053	Count down time till turning off the UPS
054	Count down time till turning on the UPS
055	User sends distant count down UPS turning on canceling command from the monitor end
056	Send battery testing command from the display panel
057	Send alarming canceling command from the display panel
058	Send turning on command from the display panel
059	Send turning off command from the display panel
061	Rectifier re-works
062	Rectifier stops working
other	Unknown error or wrong error record

4.7. RS232 intelligent communication

End definition adopts DB9 standard port

NC-----1
 RXD-----2
 TXD-----3
 NC-----4
 Signal GND-----5
 NC-----6
 NC-----7
 NC-----8
 NC-----9

2 pin: receiving end, receive computer RS-232 communication data in the UPS.

3 pin: sending end, send computer RS-232 communication data in the UPS.

5 pin: communication "GND";

Other pins: no connect.

RS-232 communication provides the following functions

Monitor UPS current power supplying status.

Monitor UPS current alarming status.

Monitor UPS current running parameters.

To control the UPS time turning on/off and set the system.

RS-232 communication data format

Baud rate ----- 2400bps

Byte ----- 8bit

Over No ----- 1bit

Parity check ----- NO

Connection of computer RS-232 and UPS RS232

Computer -----	UPS
RXD (2 pin) -----	TX (3 pin)
TXD (3 pin) -----	RX (2 pin)
GND (5 pin) -----	GND (5 pin)

4.8. RS485 intelligent communication

Port definition (from left to right)

1 pin: RS-485 communication port A(DATA+) port;
2 pin: RS-485 communication port B(DATA-) port;
3 pin: RS-485 Communication GND
4 pin: RS-485 communication port A(DATA+) port
5 pin: RS-485 communication port B(DATA-) port
6 pin: communication GND;

RS-485 communication method provides the same function with RS-232
RS-485 communication data format provides the same function with RS-232

How to connect UPS with RS-485

How to connect -----	UPS
DATA+ port -----	A port (1 pin)
DATA- port -----	B port (2 pin)
GND port -----	Communication source (3 pin)

How to connect UPS with UPS RS485

How to connect -----	UPS
DATA+ port -----	A port (1 pin)
DATA- port -----	B port (2 pin)
GND port -----	Communication source (3 pin)

4.9. Communication of SNMP and distant web

Port definition

T568A standard and T568B standard

- Ø T568A standard description order from left to right is: 1-white & green, 2-green, 3-white&orange, 4-blue, 5-white&blue, 6-orange, 7-white&brown, 8-brown
- Ø T568B standard description order from left to right is: 1-white and brown, 2-orange, 3-white&green, 4-blue, 5-white&blue, 6-green, 7-white&brown, 8-brown

SNMP card has the following function

-
- Ø Provide SNMP MIB to monitor the UPS status.
 - Ø Automatically detect and transform the 10/100M fast ETHERNET SPEED
 - Ø Set the functions through internet, web browser or NMS
 - Ø Support TCP/IP, UDP, SNMP, TELNET, SNTP, PPP, HTTP, SMTP agreements.
 - Ø Provide facility installation and updating tools which applied to MS-windows. No need the time-costing RS232 traditional way to set.
 - Ø Send SNMP TRAP, EMAIL and pager to inform the operator when battery errors.
 - Ø Can be set of sending daily history record via email.
 - Ø Able to match shutdown software to protect computer system to save documents safely and turning off the machine.
 - Ø Net Agent-3 ports generation: able to link out NETFEELER LITE environment detecting system and external modems. Also able to use the dial-up methods

4.10. Dry connect state communication

Port definition

- 1 pin: Rectifier signal is the COM port of relay
- 2 pin: Rectifier signal is the NC port of relay
- 3 pin: Bypass signal is the COM port of relay
- 4 pin: Rectifier signal is the NC port of relay
- 5 pin: Inverter signal is the COM port of relay
- 6 pin: Inverter signal is the NC port of relay
- 7 pin: DC input signal is the COM port of relay
- 8 pin: DC input signal is the NC port of relay
- 9 pin: BAT low signal is the COM port of relay
- 10 pin: BAT low signal is the NC port of relay
- 11 pin: System fault signal is the COM port of relay
- 12 pin: System fault signal is the NC port of relay
- 13 pin: Rectifier switch signal is the COM port of relay
- 14 pin: Rectifier switch signal is the NC port of relay
- 15 pin: Bypass switch signal is the COM port of relay
- 16 pin: Rectifier switch signal is the NC port of relay
- 17 pin: Inverter switch signal is the COM port of relay
- 18 pin: Inverter switch signal is the NC port of relay
- 19 pin: DC input switch signal is the COM port of relay
- 20 pin: DC input switch signal is the NC port of relay
- 21 pin: Maintain switch signal is the COM port of relay
- 22 pin: Maintain switch signal is the NC port of relay
- 23 pin: Fuse signal is the COM port of relay
- 24 pin: Fuse signal is the NC port of relay

Dry connect state communication function

- Rectifier status—signal relay turns on at the rectifier working normally
- Bypass status—signal relay turns on at the bypass working normally
- Inverter status—signal relay turns on at the inverter working normally
- DC input status—signal relay turns on at the DC inverter working normally
- BAT voltage low status—signal relay turns on at the BAT voltage low

- System fault status—signal relay turns on at the system fault
- Rectifier switch status—signal relay turns on when the rectifier switch is turned on
- Bypass switch status—signal relay turns on when the bypass switch is turned on
- Output switch status—signal relay turns on when the output switch is turned on
- DC input switch status—signal relay turns on when the DC input switch is turned on
- Maintain switch status—signal relay turns on when the maintain switch is turned on
- Fuse status—signal relay turns on when the fuse is broken

5. UPS working principle

5.1. Working principle of complete machine

I Diagram of complete machine working principle

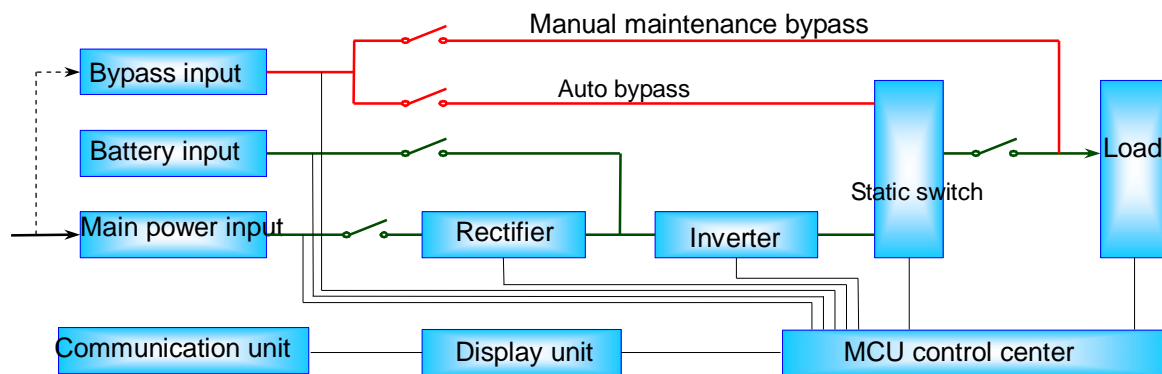

I Working principle of complete machine

UPS is multi-layer protected alternating current supply equipment. When the main power is normal, firstly, to rectify the main current and transfer it into pure direct current and filter the disturbance in main power; then charge up the accumulator and output the main power. When the main power is abnormal, to invert the direct current stocked in accumulator into alternating current and output it to ensure the high quality power supply of user load. The Manual Maintenance Bypass ensures the maintenance, examination and repair of UPS on the condition of no power cut.

I MCU control center

MCU high-speed operates such data as input, output, battery and environment; then control the running and protection of rectifier, inverter and static switch to respond the external operation instruction.

I Rectify and charge unit

Main power input examines the circuit and send the voltage, frequency and phase of main power input to MCU for operating. When the voltage, frequency and phase of main power input are within the normal range, MCU delivers the rectified control signal; rectified voltage slowly raised to rated voltage from 0V so as to minus the strike on the input surge current.

As battery pack and DC(direct current) bus is operating in parallel, rectifier is charging the battery at the same time, therefore, when battery's voltage is lower than floating battery's voltage, rectifier will operate in constant current mode. At this time, MCU will calculate and control the feedback of charge current from battery and the information of battery capacity set by user; when battery is charged into floating voltage, then rectifier will change into constant

voltage charging mode. Meanwhile, basing on the temperature of battery, MCU will charge battery in a temperature compensation style, maintain and manage battery in a regular time on the basis of its using situation (when battery hasn't been charged or discharged for a very long time, MCU will automatically transfer into an equalized charging mode in order to activate the activity of battery), thus it will extend battery's lifetime and reduce user's burden of management.

I IGBT inverter unit

When DC bus is normal, if MCU issues inverter control signal, inverter circuit will drive IGBT Inverter Bridge by SPWM driving signal, through inverter's isolation, voltage transformation and wave filtration, produce out pure sine AC (altering current). Through adjusting driving signal's pulse width, Inverter can raise output voltage from 0V to rated degree, and control stability of output through its feedback. Meanwhile, check voltage and current of output in order to protect inverter.

I Automatic and manual bypass unit

Bypass circuit can directly convert input electricity into output electricity through switch circuit. If inverter is closed or fell, MCU-controlled high-speed static switch will automatically switch into bypass electricity, without interrupt loaded power supply.

Bypass and main power can be a same group of power supply; it also can be a different AC (altering current).

I Display communication unit

Display unit is to show operational status and data of entire machine through LCD and LED, and through RS232, RS485, dry contact signal, SNMP card, etc., realize long-distance monitor with background software.

L series 1/1 adopts large-screen LCD (320×240) and touch-screen design, graphical manipulative interface, tabular data display. With 256 long records of incident, L series 1/1 can provide great help to your power supply status's analysis and management.

POCASA-styled UPS highly integrates digital technology, improves MTBF and reliability, its independent main control board controls the whole system's work. Meanwhile, it is controlled by a high-speed microprocessor, which ensures the stability of equipment and the reliability of operation.

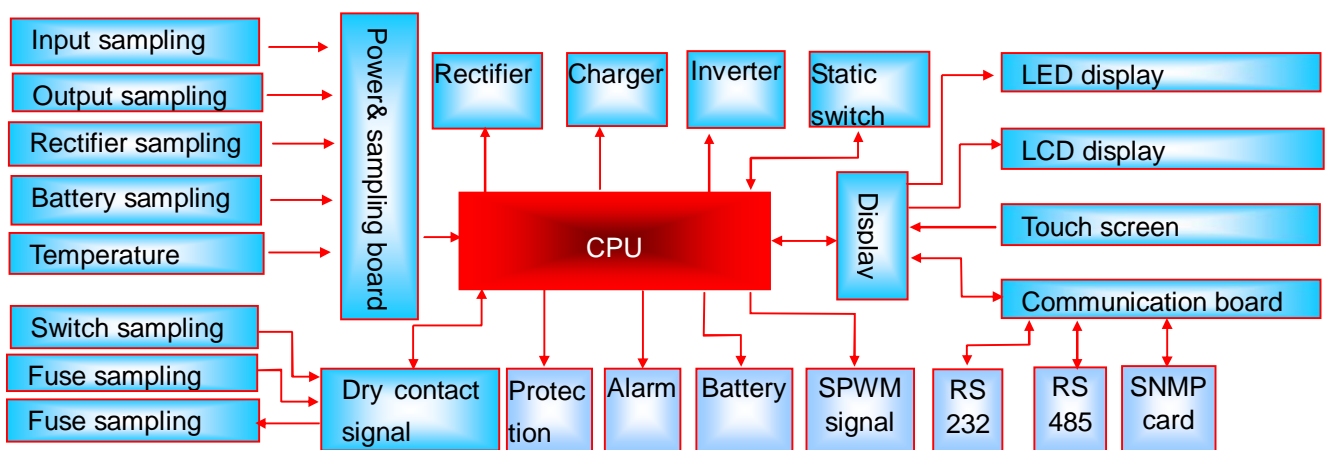

Besides the above chart, other components of UPS include: inverter transformer, input inductance, IGBT, SCR, switches, etc.

5.2. Mains operational mode

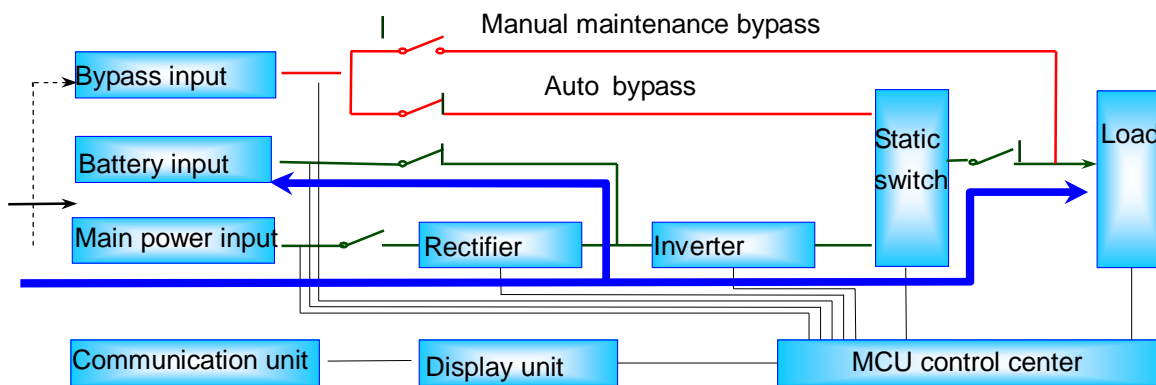

The input AC will be transformed into DC through rectification and filtering, and then through SPWM Inverter, DC outputs AC supply, through static inverter switch, AC reaches user. At the same time, DC can charge the battery pack.

5.3. Battery inverter operational mode

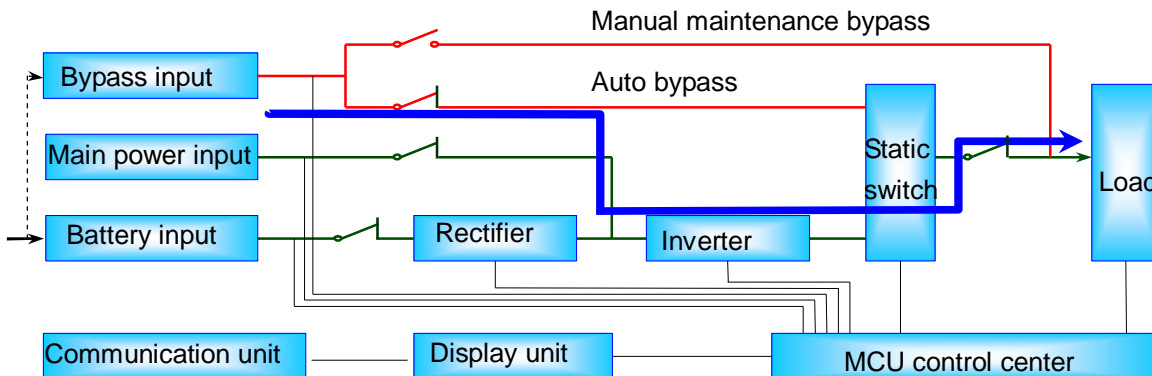

When mains become abnormal, battery will supply AC through SPWM Inverter; put it out through static inverter switch.

5.4. Bypass operational mode

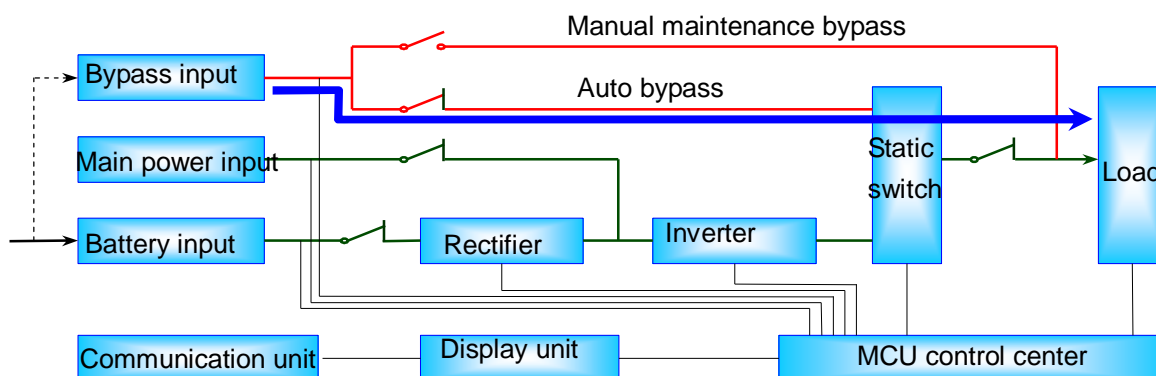

When inverter is not open or abnormal, then system will convert into bypass operational mode, AC inputs through bypass circuit, and outputs through static switch.

5.5 Manual maintenance bypass mode

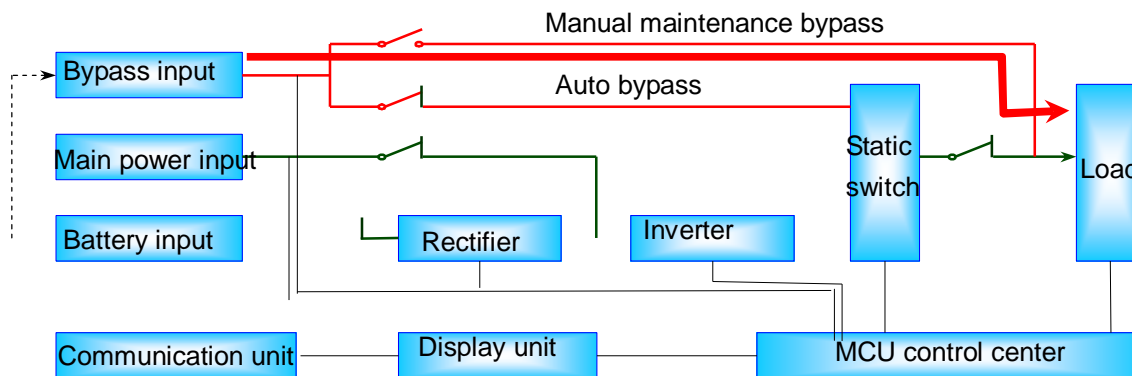

When asked on-wire maintenance without cutting power, the switch on maintenance bypass needs to be turned on, cut off the output switch and auto bypass switch, this will completely separate UPS's circuit from input and output, without interrupting users' output.

Note: when using maintenance bypass switch, must accord with operational procedures of maintenance switch!

6. UPS installation

6.1. Disassemble and inspect

- ∅ When open up packages, and take out UPS, check if it has any damage during transportation
- ∅ At the same time, make sure all the switches are cut off, UPS inside should include: warranty card, instruction, installation manual, RS232 CD-ROM, RS232 cable

6.2. UPS positioning

6.2.1. Environmental requirements of installation

- ∅ Temperature: 0°C~+40°C
- ∅ Relative humidity: 30%~90%
- ∅ Height: less than 1000 M, if height exceeds 1000M, reduce 10% usage per 1000M
- ∅ The size of installation environment should be larger at least 800 mm than the front and back, left and right size of equipment in order to convenient thermal dispersion and routine maintenance; floor force requirement: 1500 KG/M².

Ensure installation has following indoor environment.

- ∅ No dust
- ∅ A proper indoor temperature: UPS can operate under 0~40°C indoor environment, but to open it, it needs temperature to be higher than 0°C, the ideal temperature is 25°C.
- ∅ Have a good cooling system, there are some feasible methods as followings:
 - A. Natural ventilation system: only apply to low heat and broad space.
 - B. Artificial ventilation system: when temperature of machine shell (TA) higher than exterior temperature (TE), then it is necessary to install an air condition. When these two temperatures are close, the capacity of ventilation system needs to be increased relatively.

UPS is forbidden to locate at any of following conditions

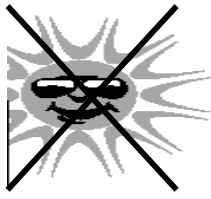

Avoid direct sunlight



Avoid raining and humidity



Far from fire and high temperature

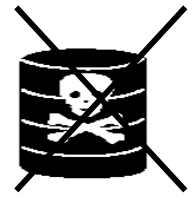

Avoid rot-gas

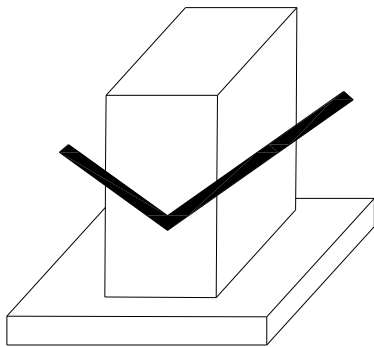

Level off

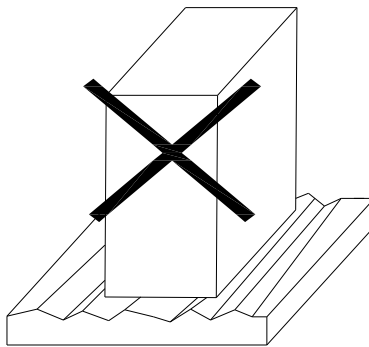

Do not place on unsmooth ground

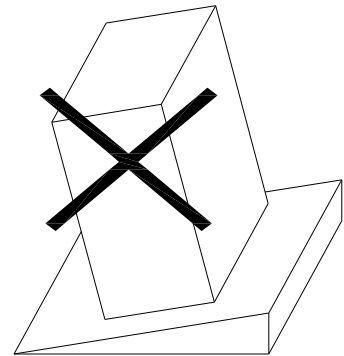

Do not place on oblique ground

6.2.2. Installation location

- ∅ Distance of machine back from wall or any object should be at least 800 mm
- ∅ At the top of UPS should not be placed any object
- ∅ The front, right and left sides of Equipment should be prepared enough space for maintenance operation
- ∅ Equipment battery should be installed in the right-hand side of machine, and reserve sufficient space for battery overhauling

6.3. UPS wires connection

6.3.1. Single phase in and out UPS series 1-30KVA recommended cable specifications: (unit: mm²)

Capacity	Input			Bypass, output		Battery	
	L	N	E	L	N	+	-
L1K	1.5	1.5	1	1.5	1.5	8	8
L2K	4	4	2.5	4	4	16	16
L3K	6	6	4	6	6	25	25
L4K	6	6	4	6	6	8	8
L6K	10	10	6	10	10	10	10
L8K	12	12	8	12	12	16	16
L10K	16	16	10	16	16	20	20
L15K	25	25	16	25	25	30	30
L20K	35	35	16	35	35	35	35
L30K	50	50	16	50	50	50	50

6.3.2. Single phase in and out UPS series UPS cable connect

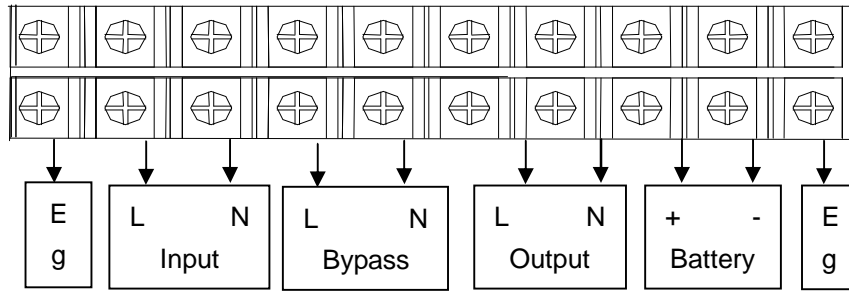

Before installing UPS, turn off all switches. According to left part of the above plan, A, B, C, N connect three-phase, separately to the fire wire and middle wire of main power input; A, B, C, N on bypass connect three-phase, separately to the fire wire and middle wire of bypass input(when one power inputs, link the main power input and bypass input together); According to right part of the above plan, A, B, C, N connect to three-phase, separately to the fire wire and middle wire of AC output.; E is connected to the safe protecting ground wire; +, - are connected to the anode and cathode of battery.

6.3.3. Battery connection

1. Before connecting battery, please check manufacturers of each battery, specifications and models, and terminal voltage to make sure whether they are in consistent (because different manufacturers' battery internal resistances are different. When battery pack run in series, because of uneven voltage, the whole battery pack can be damaged; meanwhile, the old and new batteries from same manufacturers cannot be mixed as well).
2. The input battery voltage of UPS is voltage of battery pack in series, the labeled voltage is a standard value, and it is the summation of all batteries' standard values in the battery pack running in series. For example, the standard value of a single 100AH/12VDC is 12VDC rather than measured value. The input voltage of L10K1/1 battery is 384VDC, namely, $12\text{VDC} \times 32 = 384\text{VDC}$.
3. Series and parallel connection of battery:
When the capacity of a single battery pack meet required backup time, then all the batteries should be connected in series; or couples of series connected batteries should be connected in parallel, the bus voltage of battery must be the same when connecting in parallel, capacity is equivalent to the summation of parallel battery pack.

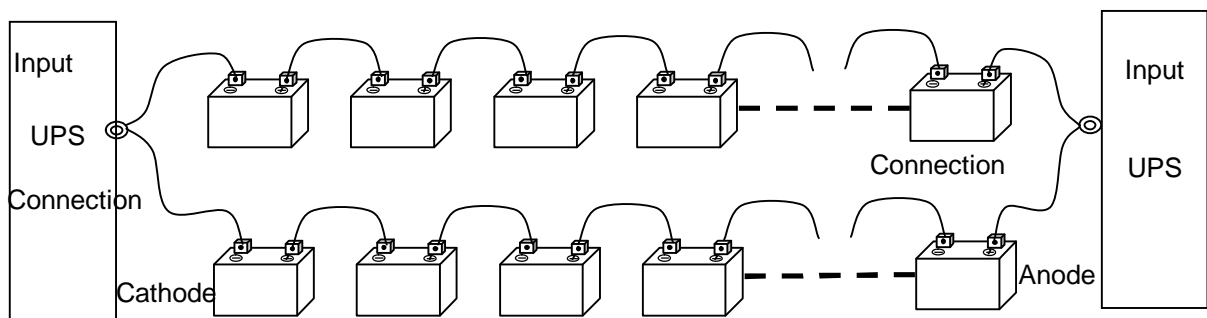

When connecting in series, the first battery's anode is connected to the second battery's cathode, the second battery's anode is connected to the second battery's cathode, and so is the other battery's connection.

When connecting in parallel, the battery pack's anodes are connected together; the battery pack's cathodes are connected together.

- ∅ Open the chassis of battery box connect according the above methods.
- ∅ Install battery on the appropriate position; connect battery wire rightly according to the above connecting methods.
- ∅ Connect the cable of battery to UPS's battery terminal board.

6.3.4. RS232 cable connections

Connect one end of DB9 signal cable which is distributed from UPS to the serial port of computer's DB9, connect the other end to the interface of UPS's RS232. If the distance is too far to connect, then you can increase the standard length of communication wire of D89, however, it should not exceeded 30 meters, or it can not communicate normally.

6.3.5. RS485 cable connection

According to UPS's A, B and G, use communication wires to connect the interfaces of computer's RS485 and UPS's RS485. The longest linking distance should be less than 4,000 m, or it can not communicate normally.

6.3.6. Connection method of SNMP card

The international standard of producing twisted-pair: EIA/TIA568A and EIA/TIA568B. Both ends of plug should follow 568 A or 568 B standard.

Network cable production:

(1) Cut: use knife-edge scissor of press line pliers to cut network cables with appropriate length.

(2) Peel: use knife-edge of press line pliers to shear cables orderly, then put wire heads on peeling blade, make wire heads touch baffle, then slightly clench pliers and slowly rotate it, let knife rip off the protecting rubber skin of twisted pair, peel off the skin (note: strip as long as thumb's length).

【Tip】 : The length between baffle and peeling blade of press line pliers usually is just same length as plug's, which can effectively avoiding peeling too long or too short. If peel too long, the network cable will look ugly, meanwhile, it can not be stuck by plug, the connection point can easily get to loose; if peel too short, because of the existing of protecting skin, cables become too thick to plug into the bottom of plug, which results in plug can not contact perfectly with cable cores. Production can not be success as well.

(3) Sort: after removing outer protecting skin, you can see four pairs of twisted-pair's eight cores, and each pair's color is different. Each pair of two allied core wires consists by one core wire stained with a corresponding color and one core wire stained with white and little corresponding color. The colors of four panchromatic core wires are: brown, orange, green and blue. Each pair is entangled with each other. When produce network cable, these four pairs of eight thin cores should be disassembled, tidied up, straightened and sorted in sequence according to the following wire order regulation.

Put the side with plastic spring of plug down, up the side with pin, make the end with pin towards to the opposite direction of yourself, the end with square hole towards to yourself, simultaneously, the far left is the first wire, the far right is the eighth wire, followed by the remaining order.

(Standard)	1	2	3	4	5	6	7	8
------------	---	---	---	---	---	---	---	---

T568A	White green	Green	White orange	Blue	White blue	Orange	White brown	Brown
T568B	White orange	Orange	White green	Blue	White blue	Green	White brown	Brown
Alignment	Same alignment	Same alignment with 6		Same alignment	Same alignment with 3		Same alignment	
T568A standard and T568B standard wire order table								

(4) Cut: straighten wires as right as possible (do not wrap), press to flat (do not overlap), tighten and tidy up (lean against each other in one direction), and then use press line pliers to cut flush. In this way, after inserting twisted pair into plug, each wire can well contact plug's pin, which avoids bad connection. If the former skin is peeled too long, then it can be cut shorter at this stage. Except outer insulation skin, the remained part is about 14 mm, which length can rightly insert each thin wire into corresponding trucking. If this part is too long, for one hand it can increase mutual crosstalk, because allied wires ate no longer twist together, for the other hand, owing to the plug can not pin the sheathes, cables derail from plug, which can cause bad connection or even Interruption.

(5) Insert: use one hand's thumb and middle finger to nip plug, the plastic shrapnel of plug faces downside, its pin towards the opposite direction of yourself, using your forefinger to hold it. Other hand nips the rubber skin which is outside of twisted pair, slowly inserts eight wires along RJ-45's eight trunkings with proper force until reaching the top of trucking.

(6) Press: when all wires are in place, and all wires' sequence is correct after thoroughly checking over through connectors, then you can use press line pliers to make RJ-45 plug. Push one head of RJ-45, from the side without teeth, into the trough of press line pliers, then clench pliers at full tilt (if your strength is not enough, you can use both hands to press), press pins which are prominent outside into plug.

Network cable connection:

One end of a well pressed network cable connects to UPS's SNMP card, the other one connects to the switch or hub of LAN (local area network).

6.4. Connection inspection

After connecting all the wires and cables, check the following items:

Whether all of battery cables are connected correctly and in a good contacting status, whether all of input, output, grounding wires have been properly connected to corresponding connation field on equipment, whether UPS's input voltage, frequency, and phase sequence are consistent with UPS's bypass voltage, frequency, and phase sequence.

7. Operation and management

7.1. Preparations before turning on the machine

- Test tool
- Millimeter
- Ammeter
- Computer for communication test

Load (actual load)

7.2. The first time turn on the UPS

Wiring inspections

Check the input line to make sure all of them meet the requirements.

Input supply test

Use millimeter to test input voltage and frequency, to make sure whether they are in the input range.

Load test

Check the output load by millimeter to make sure if there is short circuit. And calculate the loads.

Battery polarity test

Check whether the polar is right or not by millimeter and the voltage of battery belongs to the input range of UPS.

7.3. Testing in AC mode operation

Procedures of turning on the machine

Turn off the bypass switch and output switch and check whether the machine bypass is in the normal condition.

Turn off the rectification switch; the rectification will be done automatically. After that low-voltage battery indicator light will extinguish and inverter indicator will lighten, automation will become inverter running.

Turn off the battery switch, and battery will be tested by UPS. After that battery will be rectified again, when it becomes normal, use the concurrent ammeter to test charging current.

7.4. Testing in battery mode operation

Turn off the rectifier switch to simulate the inversion of battery and check whether the supply is normal.

Close the rectifier switch to change the inverter of city electricity and charge the battery.

7.5. Daily operation management

7.5.1. The opening procedures of UPS

Although the battery switch is equipped in UPS, it still must follow the following steps to open UPS:

If the commutate switch does not be turned on with 10 seconds after UPS got the power, it will alarm for wrong phase order. Please press F1 to cancel the alarm and meanwhile operate the UPS starting program as above.

7.5.2. No AC input, the battery is in inverter mode

Turn on the battery switch and press the BAT button on the panel. The panel lamp will light and UPS will be in inverter running mode. Turn on the output switch after normal inverter then it can be add load.

7.5.3. Urgency turning off program

This program only suggested to be started when fire, electricity attaching and electricity is arcing.

Cut down all the switches.

8. Daily maintaining

8.1. Defence and maintenance

-----the preventing maintaining will protect the UPS liability and long term performance.

- I Regularly check whether any of the UPS cables insulation parts is aging or broken. If yes it should be maintained immediately to avoid any safety accident.
- I UPS; Check whether the intakes are jam. There should be enough heat sink room, otherwise the UPS lifetime will be shorten even the UPS will be damaged.
- I Use the dry dishcloth (do not use wet dishcloth or liquid cleaner) to clean the UPS external dust. Should be processed without wires nearby to avoid electrical shock.
- I Check whether all the lamps work normally. The lamps status should be accordant with LCD displaying status.
- I Check whether LCD displays normally, enquiry UPS incidents records and analysis the power supply status.
- I AC work status testing
- I Battery inverter running testing
- I Battery charging testing
- I Check whether all the fasteners are fixed and whether the wires are over hot with the power cut off.

8.2. Battery maintaining





-----good maintaining towards the battery could prevent any loss when electricity is cut down accidentally or battery is low.





- I Open the battery cabinet to check whether the battery liquid is leaked and whether the port connection is loose.
- I Use the millimeter to test whether each battery voltage is accordant with each other. If any battery voltage is abnormal, it should be replaced immediately in order to avoid the damage of whole battery group.



8.3. The explanation of alarm



- I Alarm 1: switch status abnormal





If buzzer alarms and the LCD displays switch are abnormal, please check the following:



1. Rectifier switch is turned off: the LCD displays  and if changed to  please check whether the rectifier's switch is off automatically. If switch off please check whether there is output overloaded or short circuit. Switch the LCD screen to output menu to examine the output circuit, if displayed data are within prescribed range please re-start rectifier switch. The alarm will be cleaned automatically. The LCD displays  and if change to , the UPS gets right.

2. Bypass switch is turned off: the LCD displays  and if changed to  please check whether the bypass is switched off automatically. If switch off please check whether there is output overloaded or short circuit. Switch the LCD screen to output menu to examine the output circuit, if displayed data are within prescribed range please re-start bypass switch. The alarm will be cleaned automatically. The LCD displays bypass status change from  to , the UPS gets right.

3. Battery switch is turned off: the LCD displays  and if changed to  please check whether the battery's switch is off automatically. If switch off please check whether there is output overloaded or short circuit.

Switch the LCD screen to output menu to examine the output circuit, if displayed data are within prescribed range please re-start battery switch. The alarm will be cleaned automatically. The LCD displays  and if change to , the UPS gets right. Check the LCD battery displaying column for the battery voltage and charging circuit. They should be accord with battery capacity's setting.

4. Output switch is turned off: the LCD displays  and if changed to  please check whether the output's switch is off automatically. If switch off please check whether there is output overloaded or short circuit. Carefully check the load and after confirm it is normal please re-turn off the output switch. Switch the LCD screen to output menu to examine the output circuit, if displayed data are within prescribed range please re-start rectifier switch. The alarm will be cleaned automatically. The LCD displays  and if change to , the UPS gets right.

5. Breaker switch is turned off: the LCD displays  and if changed to  please check whether the commutate switch is normal. If it is normal please press F1. After cleaning the alarm please switch to inverter column and press the F2 on the panel to check whether inverter works normal. If it is also normal it is the problem of the breaker. Please replace the breaker.

I Alarm 2: input error

When the buzzer alarms 1 second with 3 seconds intermission, please check:

1. Input phase voltage is not within 165-275VAC range
2. Input frequency is not within 47.5-52.5Hz range
3. Commutate switch is not turned on.
4. Bypass switch is not turned on

I Alarm 3: wrong phase order

If buzzer alarms please check the following:

1. Main input power error or commutate input switch is cut down
2. Input main phase order errors
3. Bypass input phase order errors
4. Main power input some of the phase fault

I Alarm 4: low battery voltage

If buzzer alarms 1 second with 1 second's intermission please check:

1. Low battery voltage
2. The battery running time is less than set schedule time

I Alarm 5: inverter running errors

If buzzer alarms please check:

1. The loose connection of the inverter part leads to its abnormal work
2. Breaker is cut off and there is no AC input in the inverter
3. Inverter output is short circuit or output overload

4. Inverter output voltage beyond the prescribed range

5. Transmission errors

a. Connection cable between display panel and main panel leads to abnormal communication.

b. Main panel works abnormal and the display panel can not receive the data back from it. Please check whether the connection wires of the main panel is loose or the MCU of mail panel connect bad.

I Alarm 6: UPS overload

Buzzer alarms 3 seconds with 1 second's intermission, and the overload lamp on the panel is lighted. It means the load power is bigger than rating output power, that is, the percentage value is bigger than 100%. When overload peak value is too big, the UPS alarms. When UPS alarms, it need to lessen the load capacity. Otherwise the UPS will automatically switch to bypass power supplying, time span is calculated accord to overload value's inverse ratio.

I Alarm 7: temperature error

When buzzer alarms please check the following:

1. Cabinet airway is jam and can not
2. The installation environment's temperature is too high and beyond the machines. It protects itself.
3. Heat sink fan does not work, which leads to too hot power part.

I Alarm 8: system error

When buzzer alarms please check the following:

1. Loose main board connection cable leads to abnormal working
2. Main board setting error leads to wrong MCU receiving data.
3. Low battery voltage
4. Power board abnormality leads to controlling circuit abnormal.

I Alarm 9: commutate error

Bypass voltage error or bypass fuse SCR error, alarming when:

1. Bypass input voltage error
2. Bypass switch input switch break up
3. Bypass SCR fuse break up or be burned because of short circuit

*** On-off status abnormal**

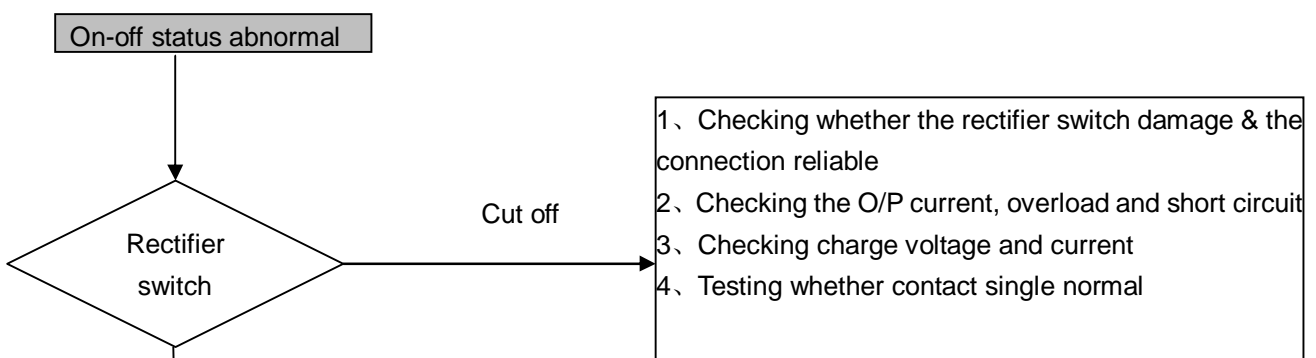

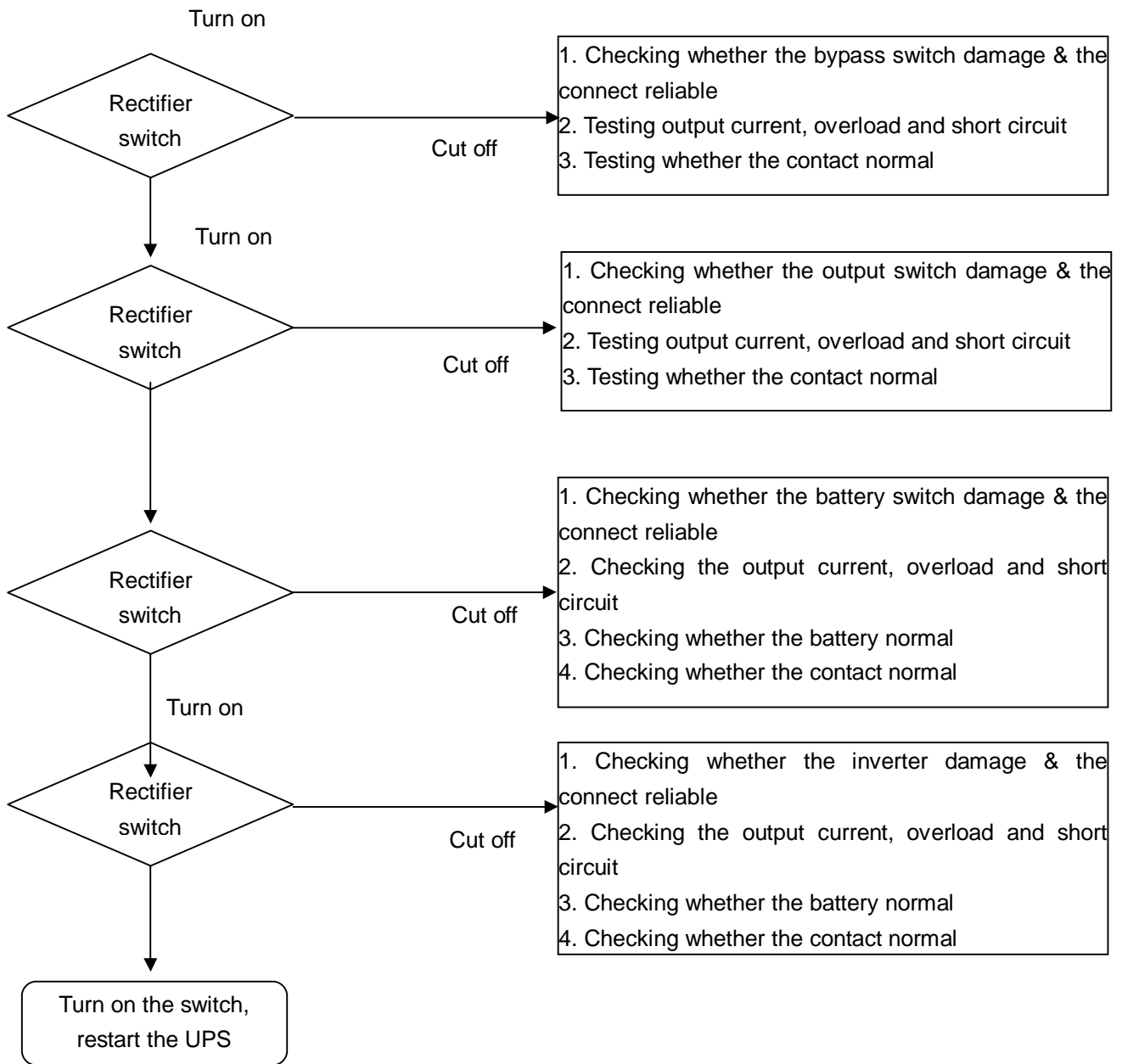

*** Input abnormal**

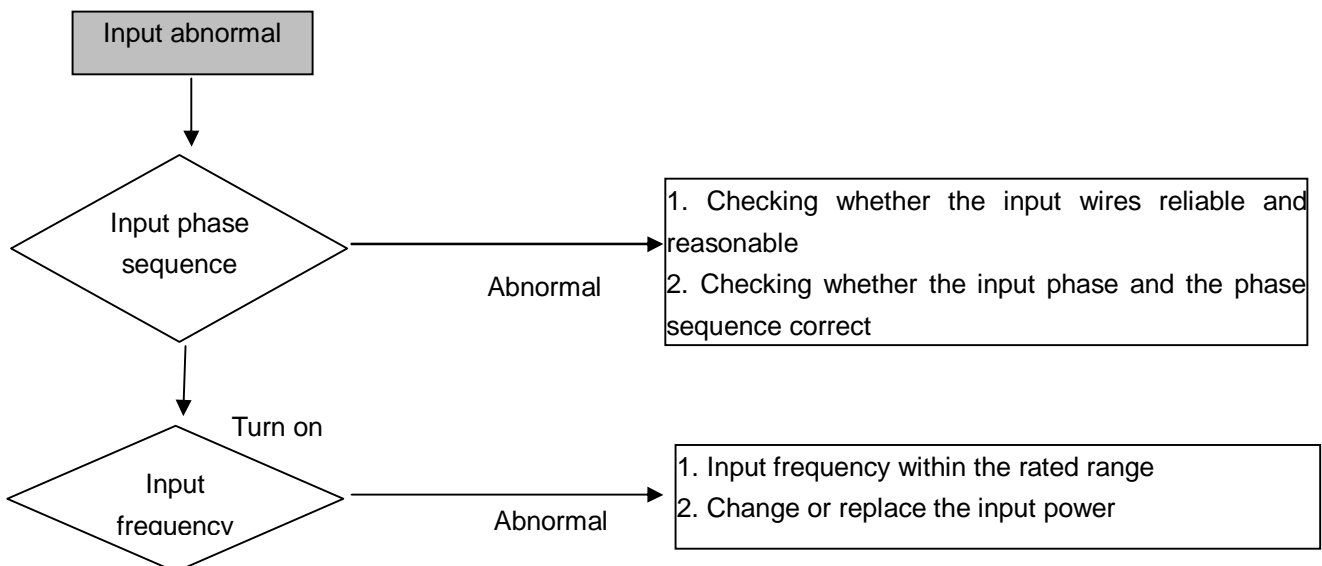

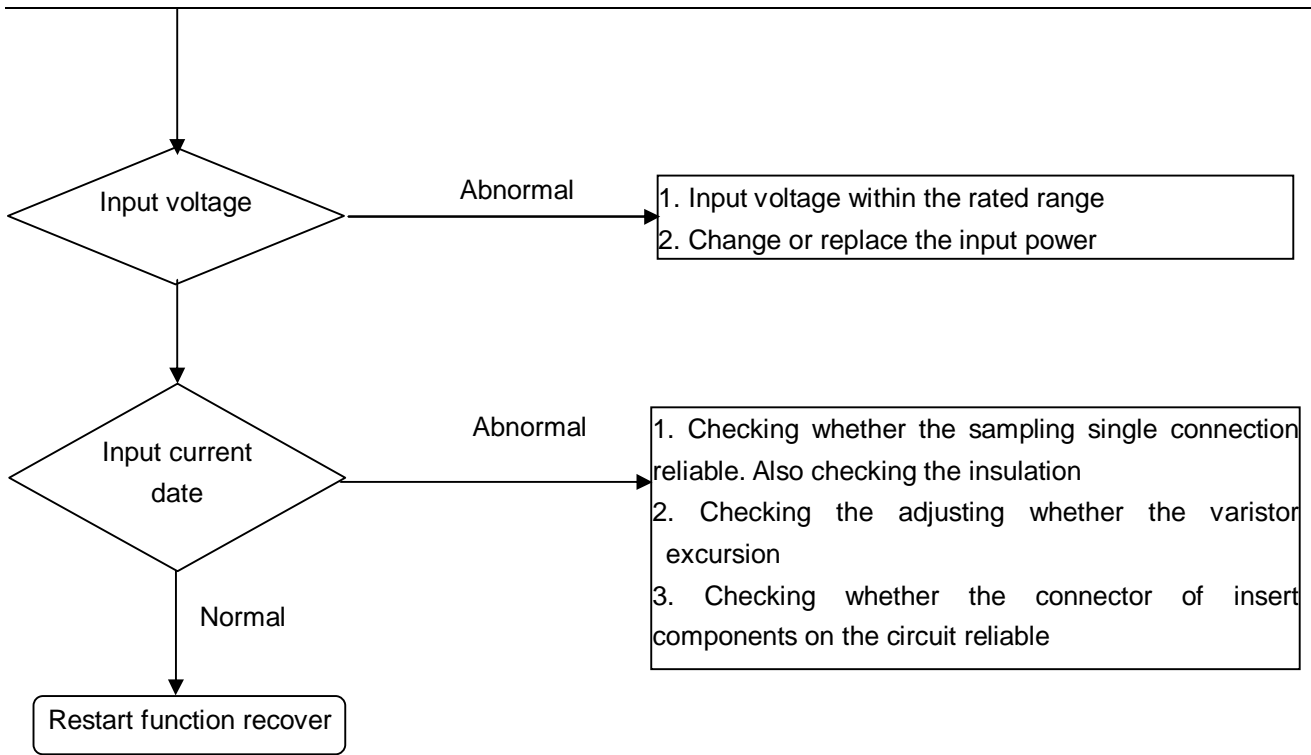

* **Phase sequence not correct**

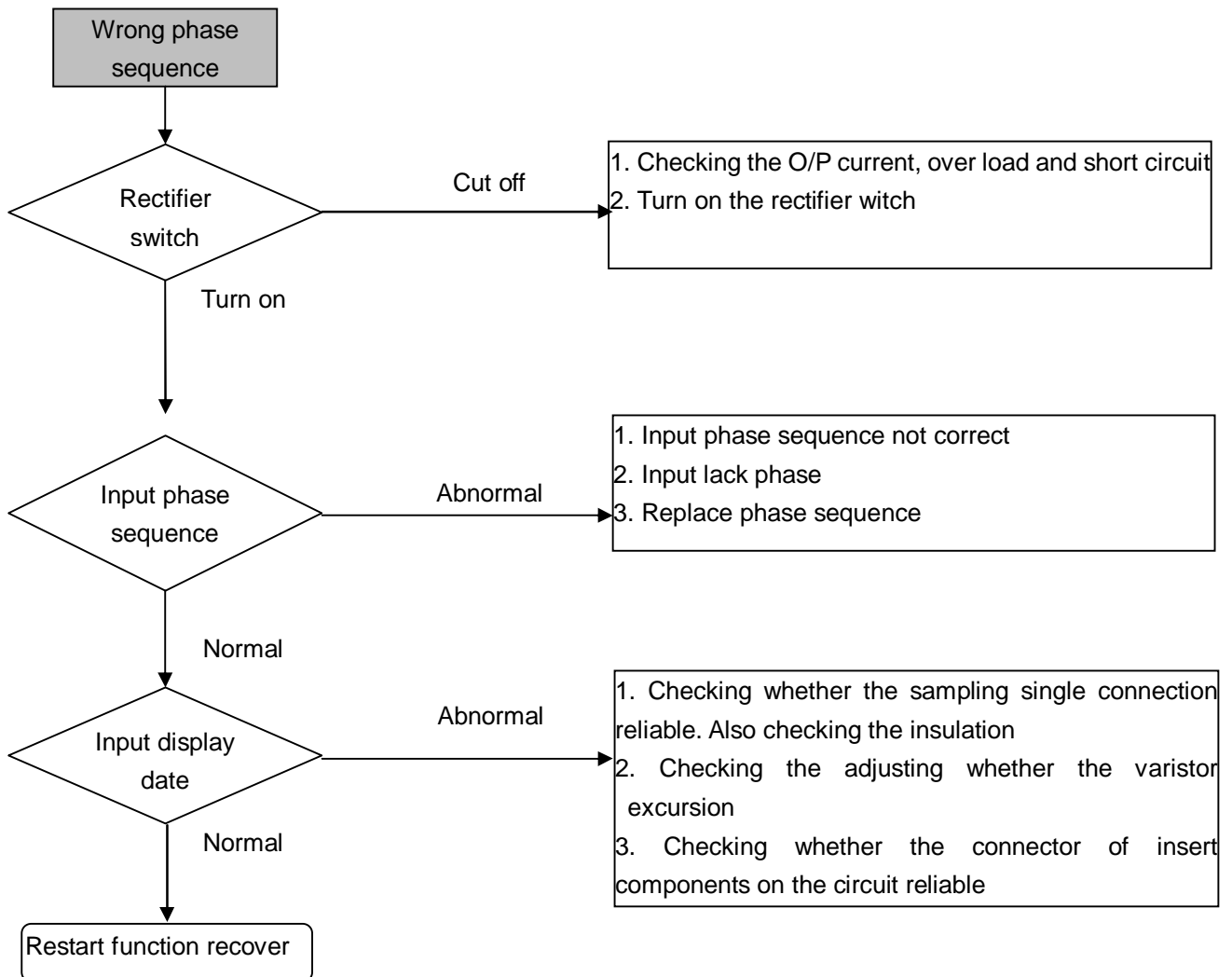

* **Battery low voltage**

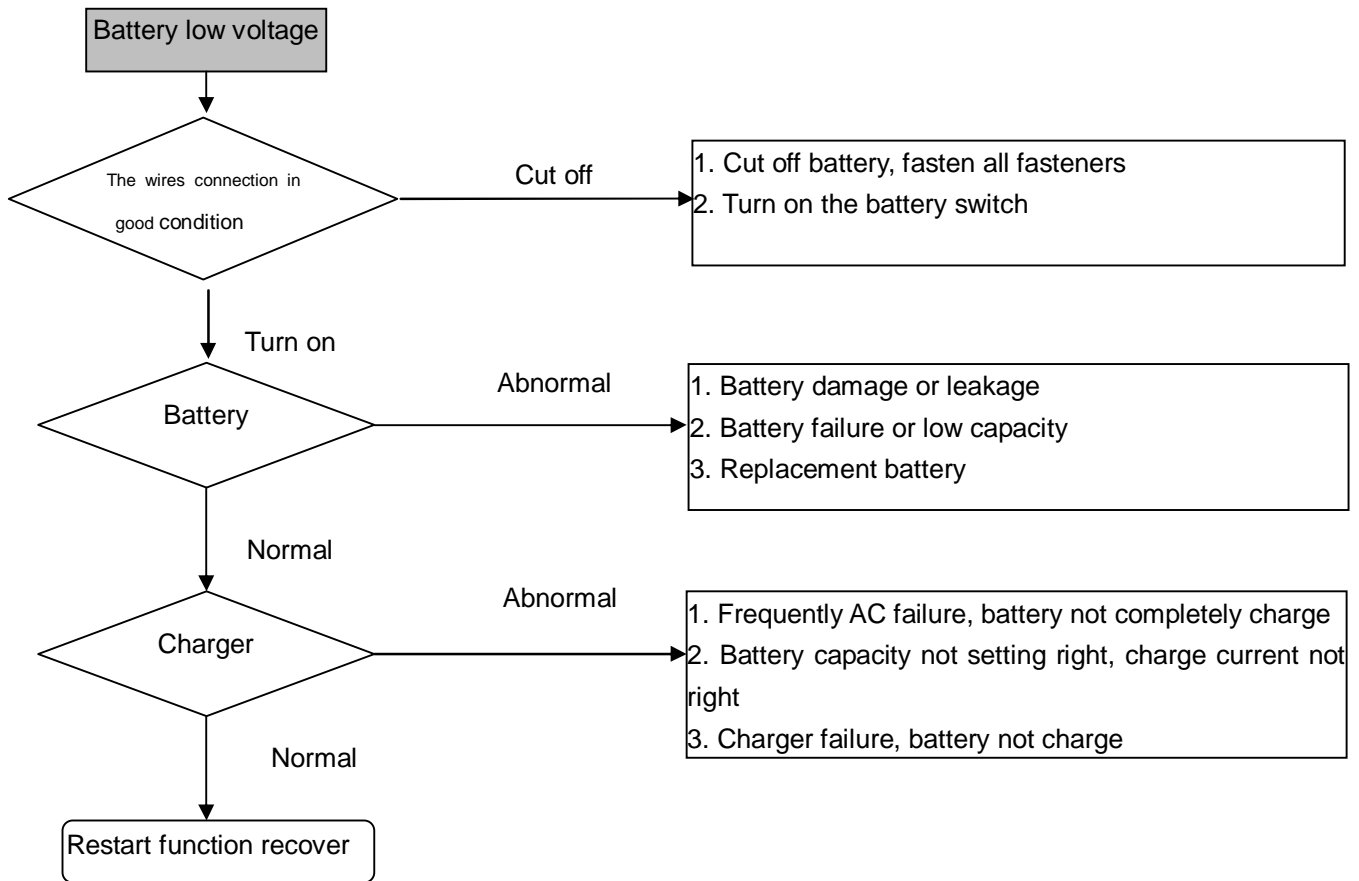

*** Inverter failure**

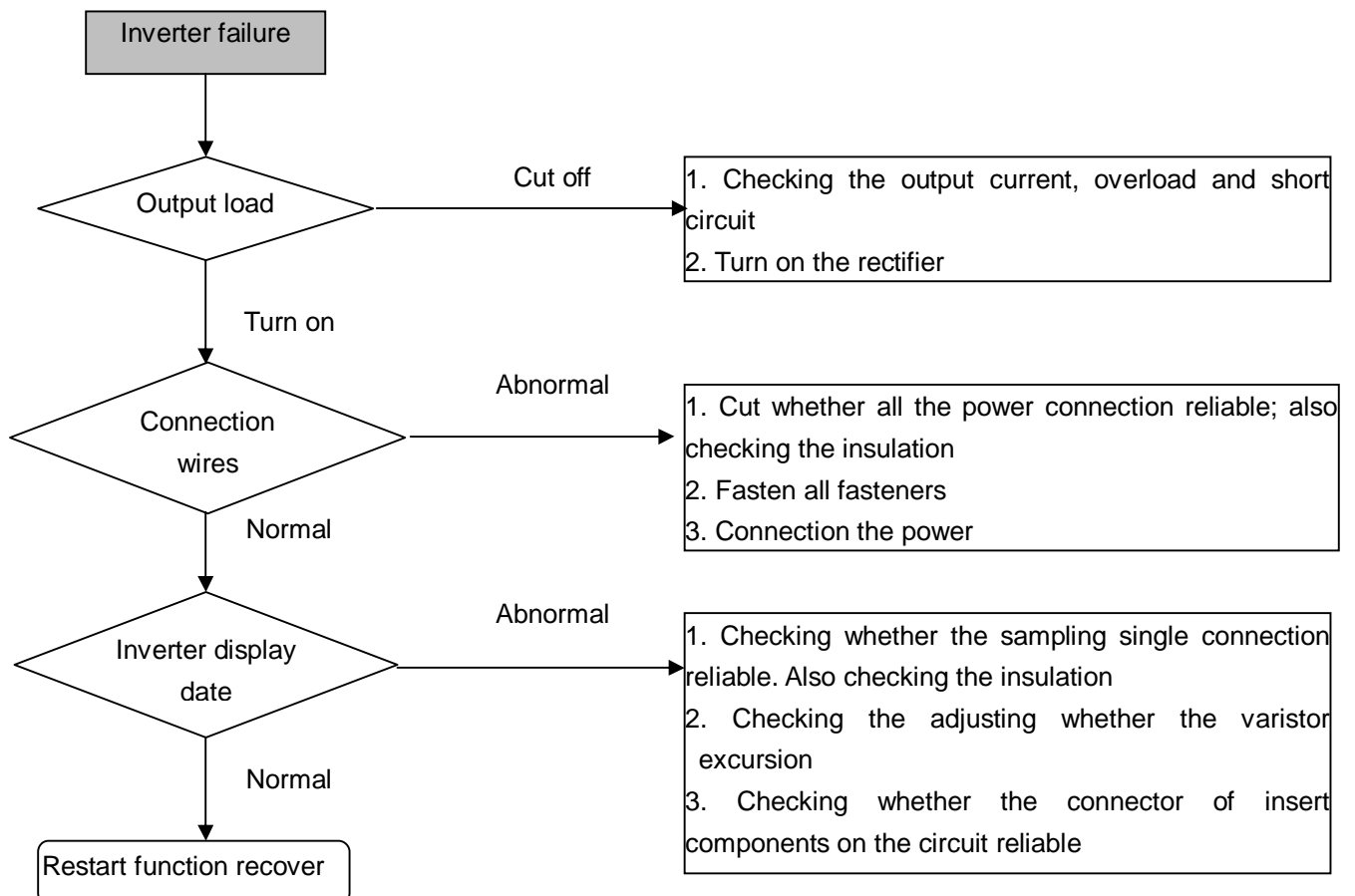

*** Output overload**

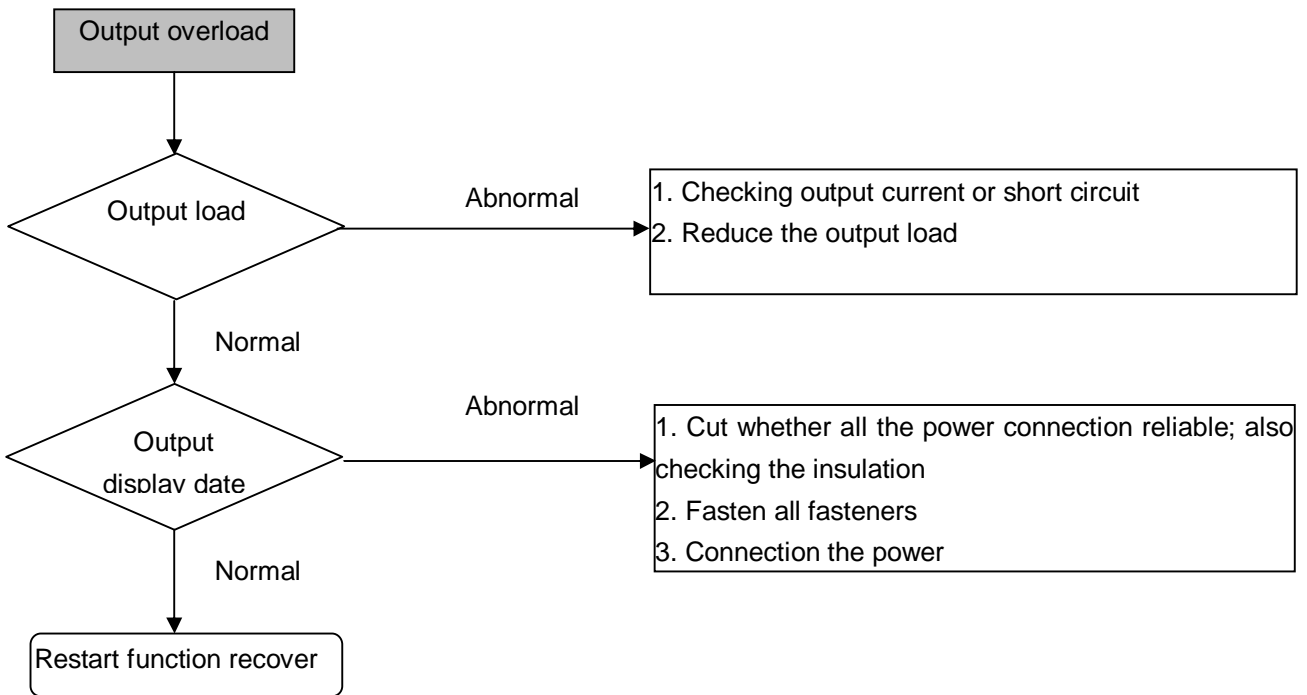

*** Temperature**

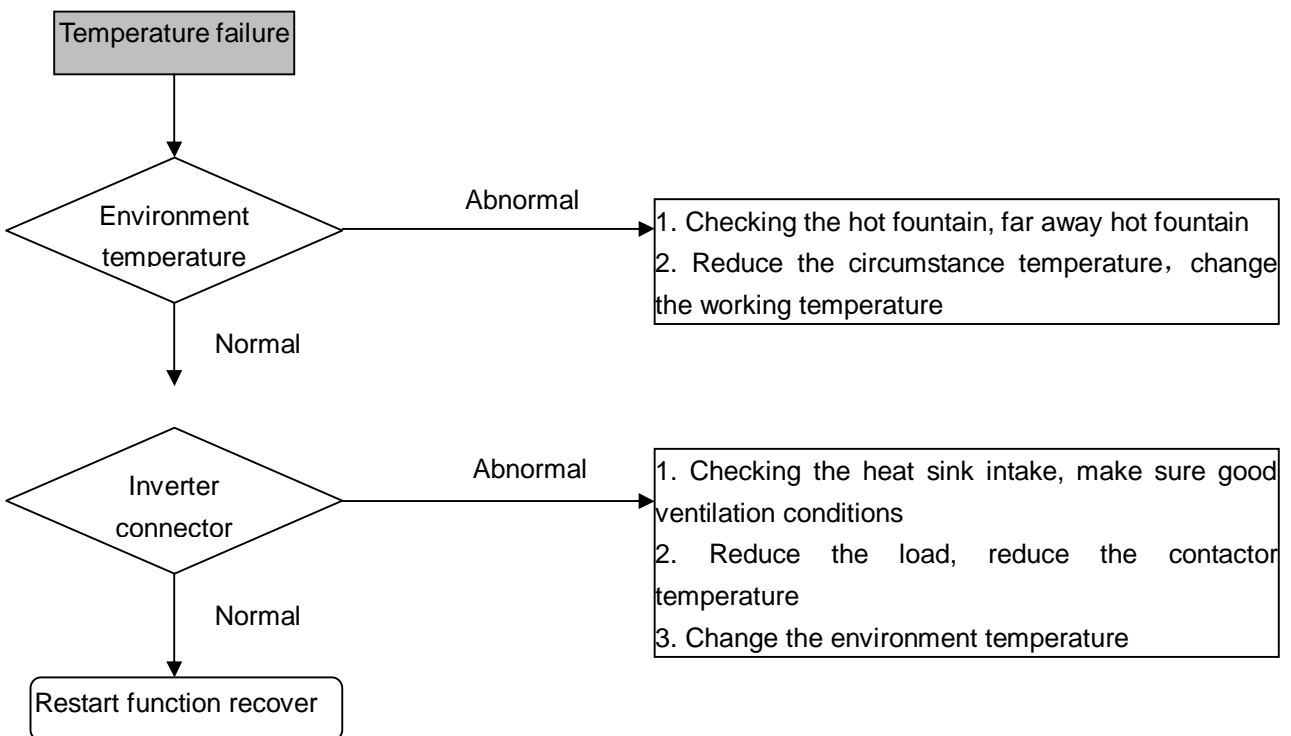

*** Transportation failure**

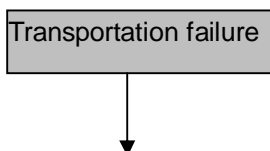

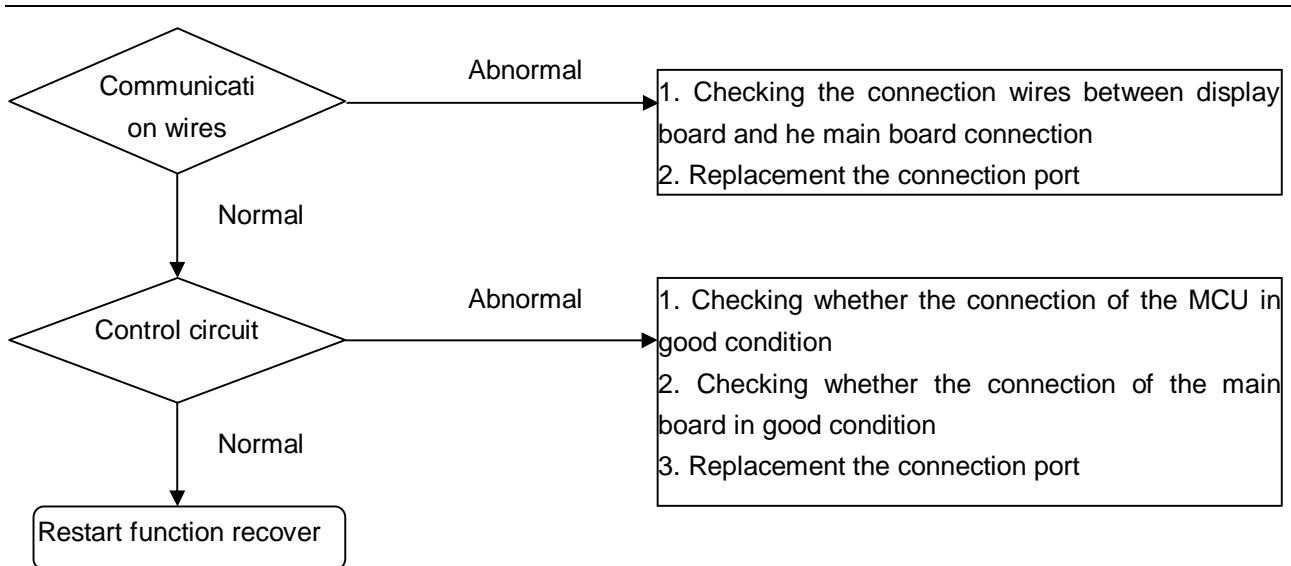

9. Packing list

S/N	Name	Quantity	Notice
1	UPS	1 pc	
2	Manual	1 pc	
3	Qualification	1 pc	
4	Installation guider	1 pc	
5			
6			

If can not understand the manual or any more detail please contacted the distributor or our company. We will zealously provide our service.

Notice: Any changing of the manual will not be informed specially.